

REV E 1062-20-01 **

REVISIONS			
SYM	DESCRIPTION	DATE	APPROVED
B	REVISED PER E.O. P17937	11-1-02	R.D.R.
C	REVISED PER E.O. P19261	6-13-06	R.D.R.
D	REVISED PER E.O. P19555	6-13-06	R.D.R.
E	REVISED PER E.O. P20392	12-3-09	RDR

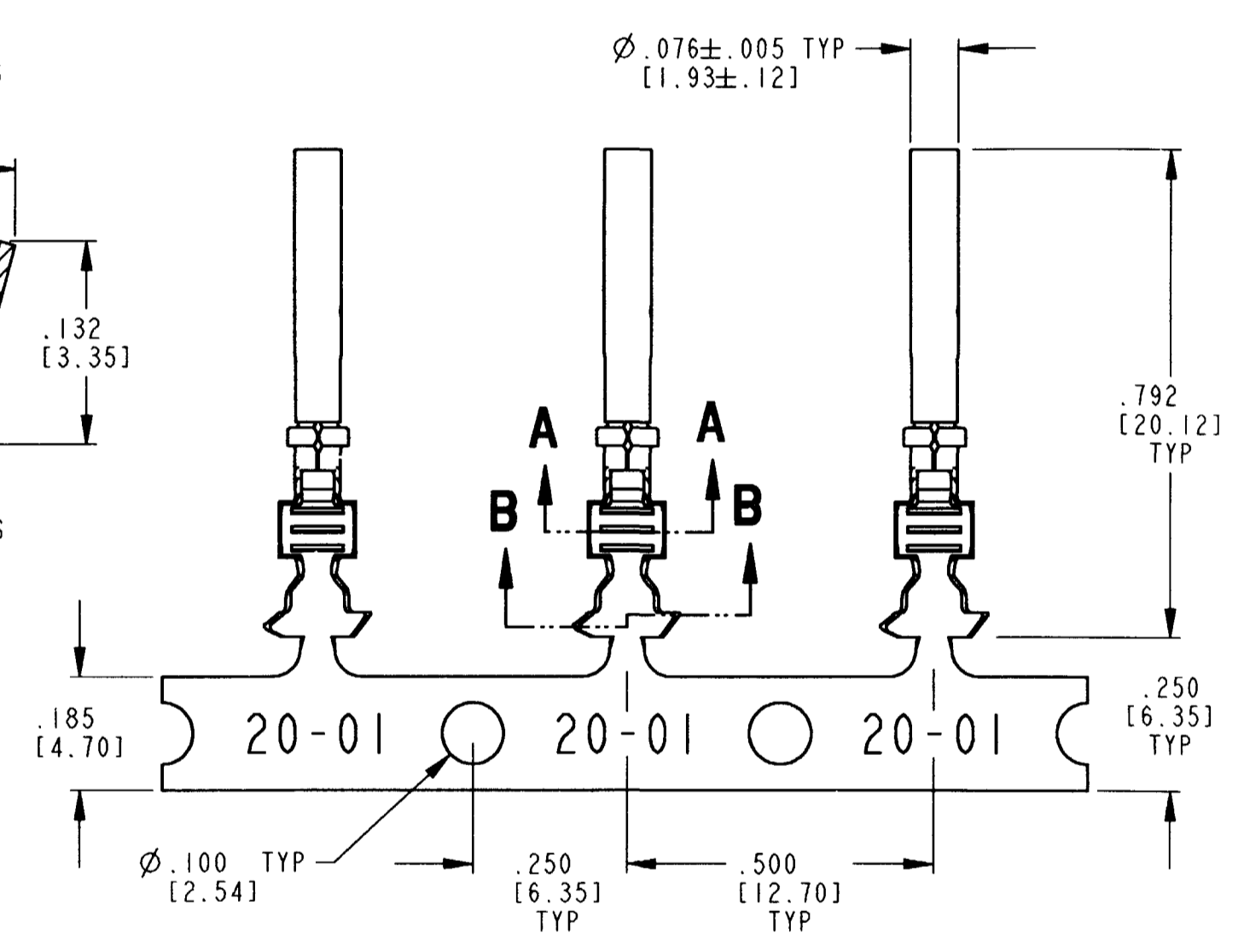

7. CONTACT BODY MATERIAL: COPPER ALLOY;
CONTACT SLEEVE MATERIAL: STAINLESS STEEL.
 6. WHEN ** = 22 PLATING IS NICKEL.
 ** = 44 PLATING IS GOLD.
 ** = 77 PLATING IS TIN.
 5. SEE 0425-015-0000 FOR CONTACT PERFORMANCE AND WIRE APPLICATION CHARACTERISTICS.
 4. THIS CONTACT MAY BE CRIMPED WITH DCT20-02-00 AUTOMATIC DIE OR DTT-20-00 HAND TOOL. SEE DRAWING 0425-207-0000 FOR APPLICABLE WIRE SIZE, INSULATION DIAMETER RANGE, AND CRIMPING INFORMATION.
 3. ONE REEL CONTAINS APPROXIMATELY 4000 CONTACTS.
 2. DIMENSIONAL TOLERANCE: ±.025 [0.63].
 1. DIMENSIONS ARE IN INCHES [mm].
- NOTES: UNLESS OTHERWISE SPECIFIED

SIGNATURE & DATE	
DR	J. APOSTOL 01DEC2009
CHK	D. May 12/09
PE	D. May 12/09
APPD	R. Reed 12-3-09
SCALE	NONE
WT	

STAMPED CONTACT SOCKET SIZE 20

ENVELOPE

EP	MATL. CODE
3850 INDUSTRIAL AVE. HEMET, CA 92545	
B 1062-20-01 **	
DWG SIZE	CODE 11139 SHEET OF