

METRIC
 DIMENSIONS LISTED IN mm [INCHES]

AMP WIRE RANGE 12-10 AWG STRAINED	UL E13288 Listed
LR7189 Certified	MILITARY P/N AND CLASS
NOT CERTIFIED	NOT APPLICABLE

△ STAMP AMP 12-10* APPROX AS SHOWN

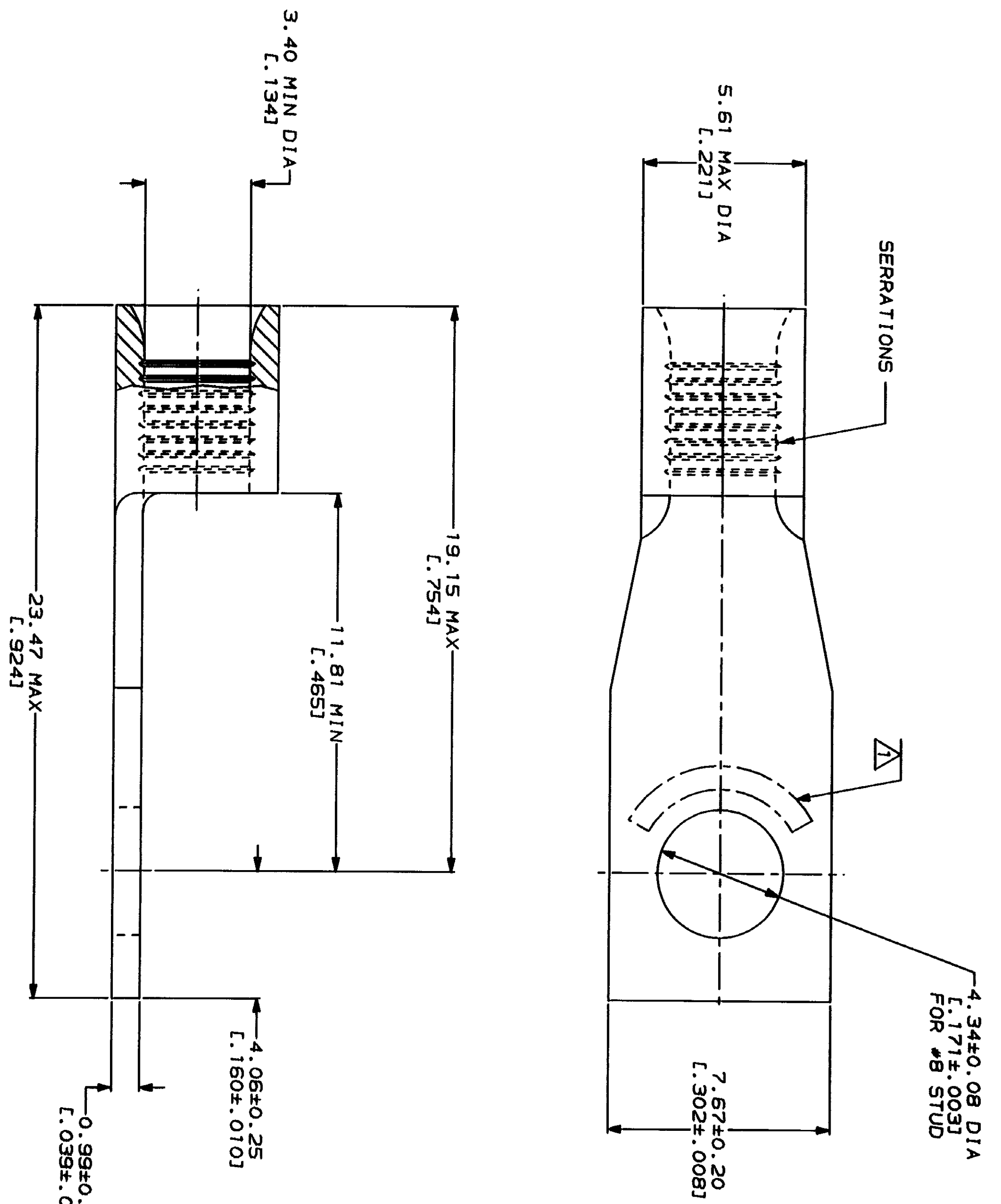

AMP INCORPORATED
 CUSTOMER SERVICE SYSTEMS

FOR ADDITIONAL
 PRODUCT INFORMATION OR
 COPIES OF DRAWINGS
 AND TECHNICAL DOCUMENTS
 1-800-522-6752

FOR APPLICATION
 TOOLING INFORMATION
 1-800-722-1111

FOR ORDER ENTRY
 1-800-526-5142

MAX RECOMMENDED OPERATING
 TEMPERATURE:
 170°C MAX

VOLTAGE RATING:
 NOT APPLICABLE

WIRE CROSS SECTIONAL AREA RANGE:
 2.62-6.64mm² [5, 180-13, 100] CIR MILS
 STRAINED

DO NOT SCALE PRINT.
 UNLESS SPECIFIED
 DIMENSIONS IN INCHES
 TOLERANCES ON:
 2 PLC DEC ± .005
 3 PLC DEC ± .002
 ANGLES
 MATERIAL
 COPPER PER
 ASTM B-152
 ANNEALED

FINISH
 TIN PLATE
 0.0025±[L. 000100] MIN
 THK PER MIL-T-10727

DR 1-29-93
 TA BRINKMAN

CHK 1-29-93
 DA PATTERSON

APPD 1-29-93
 DE MILLER

APPD 1-29-93
 JL HOCKLEY

AMP
 AMP Incorporated
 Harrisburg, PA 17105-3608

TERMINAL, RECTANGULAR
 TONGUE, BUDGET

APPLICATION SPEC

SCALE 8:1

SIZE CAGE CODE DRAWING NO
 00779 G-331269

WEIGHT SHEET 1 OF 1

331269
 PART NO

331269