

DRAWING MADE IN THIRD ANGLE PROJECTION

© COPYRIGHT 1973 BY AMP INCORPORATED, HARRISBURG, PA. ALL INTERNATIONAL RIGHTS RESERVED. AMP INCORPORATED PRODUCTS COVERED BY U. S. AND FOREIGN PATENTS AND/OR PATENTS PENDING.

LOC JIST
R 39

REVISIONS						
P	F	ZONE	LTR	DESCRIPTION	DATE	APPROVED
			O	RELEASED	10-23-73	[Signature]
			A	ADDED -3 ECN C-675	11/24/73	[Signature]
			B	REV. PER ECN C-703	12/11/73	[Signature]
			C	REV. PER ECN C-981	5/11/74	[Signature]
			D	ADDED -4 PER ECN C-663	1/22/75	[Signature]
			E	ADDED -5 & -6 PER ECN E-685	10/21/76	[Signature]
			F	.045 WAS .050 ECN F-055	5/14/77	[Signature]
			G	REV. PER ECN G-132	11/17/77	[Signature]
			H	REV. PER ECN J-877	1/30/82	[Signature]
			J	REV. PER ECN K-550	2/22/82	[Signature]
			K	REV. PER ECN R-2586	1-14-87	[Signature]
			L	OBSOLETE -4, -5 & -6 / R-2520	1-21-87	[Signature]

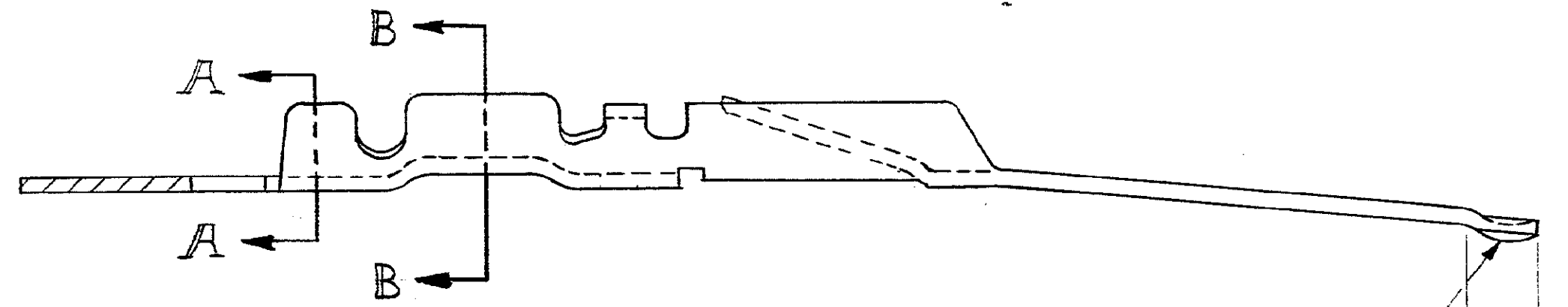
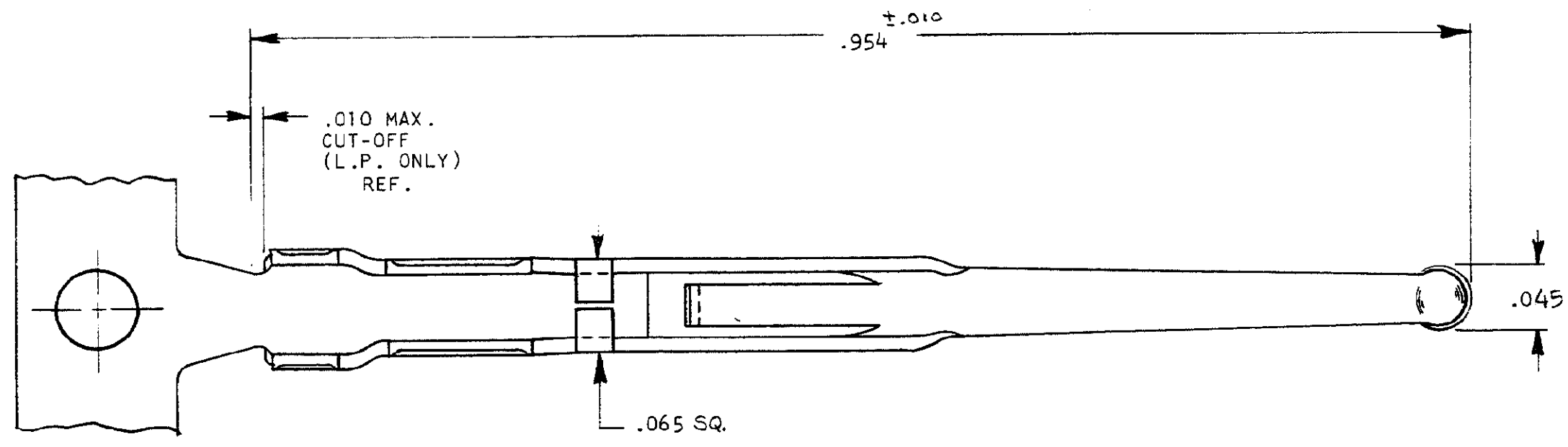

- 66555-2 1. AS SHOWN:
- 66555-3 1. SAME AS -2 EXCEPT:
2. LOOSE PIECE
- ~~OBSOLETE~~ SAME AS -2 EXCEPT:
2. REVERSE REEL
- ~~OBSOLETE~~ SAME AS -2 EXCEPT Δ
- ~~OBSOLETE~~ SAME AS -5 EXCEPT:
2. LOOSE PIECE

.050 MIN. SELECTIVE GOLD PLATE AREA, CONTACT SIDE ONLY

PLATING THICKNESS MEASUREMENT POINT

- Δ SELECTIVELY PLATE GOLD PER MIL-G-45204 OVER NICKEL PER QQ-N-290.
- Δ SELECTIVELY PLATE .000050 GOLD PER MIL-G-45204 OVER NICKEL PER QQ-N-290.

STOCK THICKNESS: $\pm .0005$
.0126

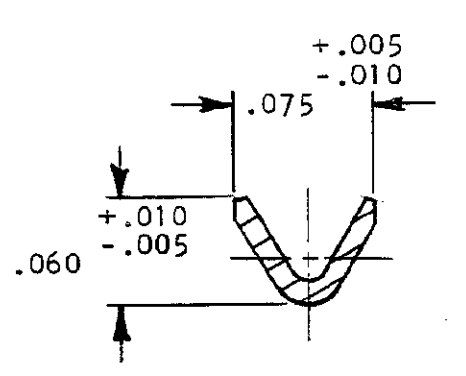

SECTION B-B

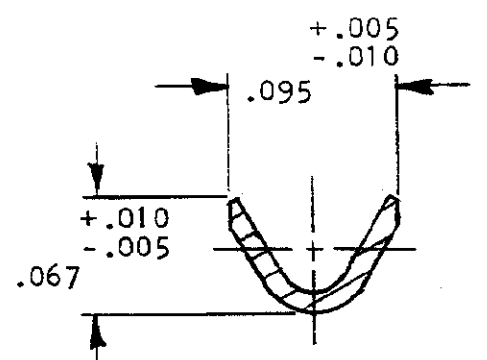

SECTION A-A

UNLESS OTHERWISE SPECIFIED DIMENSIONS ARE IN INCHES. TOLERANCES ON: DECIMALS $\pm .005$ ANGLES \pm	CONTRACT NO DR [Signature] 10-23-73	PART NO	
	CHK [Signature] 10/20/73	AMP INCORPORATED Harrisburg, Pa.	
MATERIAL COPPER ALLOY PER QQ-B-750	APPD [Signature] 10-23-73	NAME ACTIVE CONTACT -STRIP-	
FINISH SEE CALL OUT	APPR [Signature] 10/23/73	SIZE CODE IDENT NO C 00779	DRAWING NO 66555
	OTHER APPD	SCALE 10-1	SHEET 1 OF 1

CUST. B 66555

CUSTOMER DRAWING