

3-Phase Brushless DC Motor Pre-Driver

Features and Benefits

- Drives 6 N-channel MOSFETs
- Synchronous rectification for low power dissipation
- Internal UVLO and thermal shutdown circuitry
- Hall element inputs
- PWM current limiting
- Dead time protection
- FG outputs
- Standby mode
- Lock detect protection
- Overvoltage protection

Package: 32-contact QFN (suffix ET)

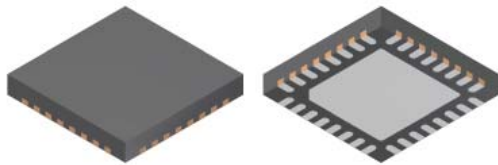

Not to scale

Description

The A4936 is a complete 3-phase brushless DC motor pre-driver, supplying up to 28 V output for direct, high-current gate drive of an all N-channel power MOSFET 3-phase bridge. The device has three Hall-element inputs, a sequencer for commutation control, fixed off-time pulse width modulation (PWM) current control, and locked-rotor detection.

Output current is scaled by the capability of the external MOSFETs. Locked rotor detection delay is set by an external capacitor on the CLD terminal. The PWM, DIR, and BRAKE and STOP inputs can be used to control motor speed, position, and torque. Motor speed can be determined using the FG output from an FG coil amplifier and comparator.

The external MOSFETs can be PWMed using an external signal on the PWM input, or using the internal PWM current regulator. In either case, the A4936 synchronous rectification feature reduces power dissipation by turning-on the appropriate MOSFETs during current decay.

The Hall elements can be inexpensive types, when used with noise filtering to prevent false commutation signals. The A4936 provides a regulated 7.5 V supply to power the three Hall elements.

Continued on the next page...

Typical Application Diagram

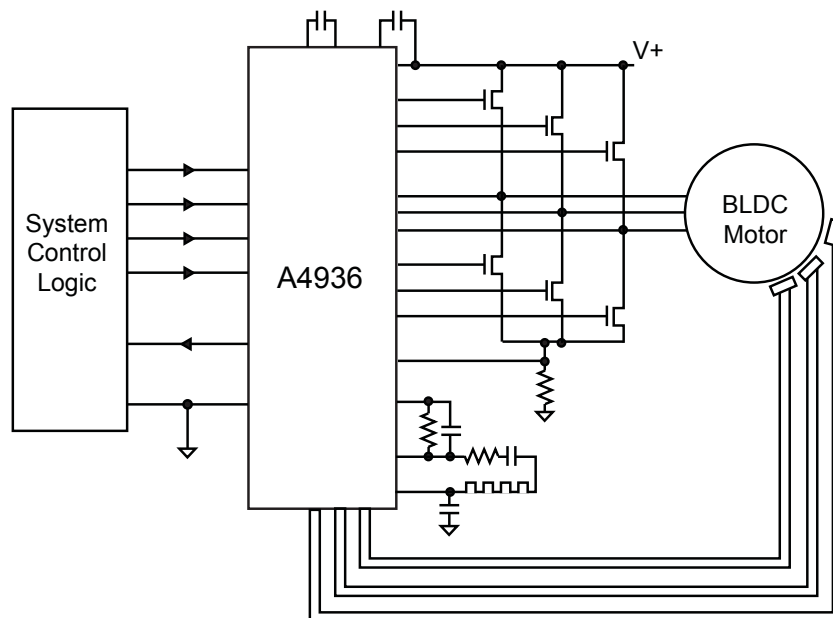

Description (continued)

Internal circuit protection includes thermal shutdown with hysteresis, undervoltage lockout, and dead time protection. Special power-up sequencing is not required. Operating temperature range is -20°C to 105°C .

The device package is a 32-contact, $5\text{ mm} \times 5\text{ mm}$, 0.90 mm nominal overall height QFN, with exposed pad for enhanced thermal dissipation. This small-footprint package is lead (Pb) free, with 100% matte tin leadframe plating.

Selection Guide

Part Number	Packing*	Package
A4936MET-T	73 pieces per tube	32-pin QFN, $5\text{ mm} \times 5\text{ mm}$, 0.90 mm nominal overall height
A4936METTR-T	1500 pieces per reel	

*Contact Allegro™ for additional packing options

Absolute Maximum Ratings

Characteristic	Symbol	Notes	Rating	Unit
Load Supply Voltage	V_{BB}		38	V
Motor Phase Output	S_x	$t_w < 500\text{ ns}$	-3	V
Hall Input	V_{Hx}	DC	-0.3 to 7	V
Logic Input Voltage Range	V_{IN}		-0.3 to 7	V
Ambient Operating Temperature	T_A	Range M	-20 to 105	$^{\circ}\text{C}$
Maximum Junction Temperature	$T_{\text{J(max)}}$		150	$^{\circ}\text{C}$
Storage Temperature	T_{stg}		-40 to 150	$^{\circ}\text{C}$

Thermal Characteristics may require derating at maximum conditions, see application information

Characteristic	Symbol	Test Conditions*	Value	Unit
Package Thermal Resistance (Junction to Ambient)	$R_{\theta\text{JA}}$	On 4-layer PCB based on JEDEC standard	32	$^{\circ}\text{C}/\text{W}$
Package Thermal Resistance (Junction to Exposed Pad)	$R_{\theta\text{JP}}$		2	$^{\circ}\text{C}/\text{W}$

*Additional thermal information available on the Allegro website

Functional Block Diagram

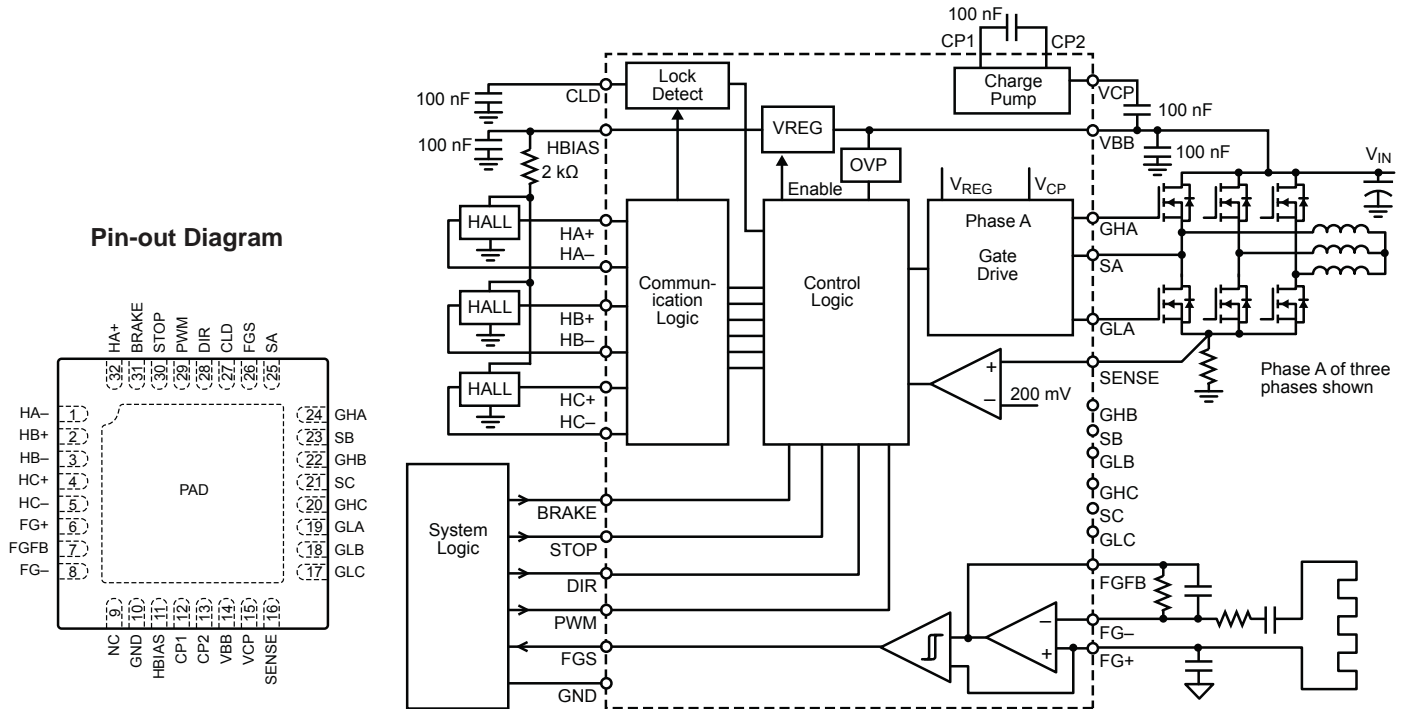

Terminal List Table

Number	Name	Function	Number	Name	Function
1	HA-	Hall input A	18	GLB	Low-side gate drive B
2	HB+	Hall input B	19	GLA	Low-side gate drive A
3	HB-	Hall input B	20	GHC	High-side gate drive C
4	HC+	Hall input C	21	SC	High-side source connection C
5	HC-	Hall input C	22	GHB	High-side gate drive B
6	FG+	FG input	23	SB	High-side source connection B
7	FGFB	FG amplifier feedback output	24	GHA	High-side gate drive A
8	FG-	FG input	25	SA	High-side source connection A
9	NC	No internal connection	26	FGS	FG output
10	GND	Ground	27	CLD	Locked rotor detect timing capacitor
11	HBIAS	Hall bias power supply output	28	DIR	Logic input: motor direction
12	CP1	Charge pump capacitor terminal	29	PWM	Logic input: external PWM control
13	CP2	Charge pump capacitor terminal	30	STOP	Logic input: output disable
14	VBB	Supply voltage	31	BRAKE	Logic input: motor brake
15	VCP	Reservoir capacitor terminal	32	HA+	Hall input A
16	SENSE	Sense resistor connection	-	PAD	Exposed Thermal Pad
17	GLC	Low-side gate drive C			

ELECTRICAL CHARACTERISTICS^{1,2} Valid at $T_A = 25^\circ\text{C}$, $V_{IN} = 24\text{ V}$; unless otherwise noted

Characteristics	Symbol	Test Conditions	Min.	Typ. ³	Max.	Unit
General						
Supply Voltage Range	V_{BB}	Operating	8.5	–	V_{BBOV}	V
Motor Supply Current	I_{BB}	$f_{PWM} < 30\text{ kHz}$, $C_{LOAD} = 1000\text{ pF}$	–	5.1	6.5	mA
		Standby mode	–	3	4	mA
HBIAS	V_{HBIAS}	$0\text{ mA} \leq I_{HBIAS} \leq 24\text{ mA}$	7.2	7.5	7.8	V
HBIAS Current Limit	$I_{HBIASlim}$		30	–	–	mA
Control Logic						
Logic Input Voltage	$V_{IN(1)}$		2	–	–	V
	$V_{IN(0)}$		–	–	0.8	V
Logic Input Current	$I_{IN(1)}$	$V_{IN} = 2\text{ V}$	–1.0	<1.0	1.0	μA
	$I_{IN(0)}$	$V_{IN} = 0.8\text{ V}$	–1.0	<–1.0	1.0	μA
Input Pin Glitch Reject	t_{GLITCH}	PWM pin	350	500	650	ns
		DIR, BRAKE, and STOP pins	700	1000	1300	ns
HBIAS Wake-up Delay, Standby Mode	t_{dHBIAS}	$C_{HBIAS} = 0.1\text{ }\mu\text{F}$	–	15	25	μs
Gate Drive						
High-Side Gate Drive Output	$V_{GS(H)}$	Relative to V_{BB} , $I_{GATE} = 2\text{ mA}$	7	–	–	V
Low-Side Gate Drive Output	$V_{GS(L)}$	$I_{GATE} = 2\text{ mA}$	7	–	–	V
Gate Drive Current (Sourcing)	I_{GATE}	$GHx = GLx = 4\text{ V}$	20	30	–	mA
Gate Drive Pull-Down Resistance	R_{GATE}		10	28	40	Ω
Dead Time	t_{DEAD}		700	1000	1300	ns
Current Limit Input Threshold	V_{REF}		180	200	220	mV
Fixed Off-Time	t_{OFF}		18	25	37	μs
Protection						
Thermal Shutdown Temperature	T_{JTSD}		155	170	185	$^\circ\text{C}$
Thermal Shutdown Hysteresis	$T_{JTSDhys}$		–	20	–	$^\circ\text{C}$
VBB UVLO Enable Threshold	V_{BBUV}	Rising V_{BB}	6.2	7	7.85	V
VBB UVLO Hysteresis	$V_{BBUVhys}$		0.4	0.75	1	V
VCP UVLO	V_{CPOV}	Relative to V_{BB} , VCP falling	4.6	–	6	V
Lock Detect Duration	t_{lock}	$C = 0.1\text{ }\mu\text{F}$	1.5	2	2.5	s
VBB Overvoltage Threshold	V_{BBOV}	Rising V_{BB}	30	33	37.5	V
Hall Logic						
Hall Input Current	I_{HALL}	$V_{IN} = 0.2\text{ to }3.5\text{ V}$	–1	0	1	μA
Common Mode Input Range	V_{CMR}		0.2	–	3.5	V
AC Input Voltage Range	V_{HALL}		60	–	–	mV _{p-p}
Hall Thresholds	V_{th}	Difference between Hall inputs at transitions	–	+10, –10	–	mV
Hall Threshold Hysteresis	V_{HYS}	$T_J = 25^\circ\text{C}$	10	20	30	mV
		$T_J = -20^\circ\text{C to }125^\circ\text{C}$	5	20	40	mV
Pulse Reject Filter	t_{pulse}		–	2	–	μs

Continued on the next page...

ELECTRICAL CHARACTERISTICS^{1,2} (continued) Valid at $T_A = 25^\circ\text{C}$, $V_{IN} = 24\text{ V}$; unless otherwise noted

Characteristics	Symbol	Test Conditions	Min.	Typ. ³	Max.	Unit
FG						
FG Input Bias Current	I_{BFG}		-1	-	1	μA
FG Input Offset Voltage	V_{OSFG}		-15	-	15	mV
FGS Output High Leakage	I_{OH}	$V_{OH} = 5\text{ V}$	-1	-	1	μA
FGS Output Low Voltage	V_{OL}	$I_{OL} = 2\text{ mA}$	-	0.2	0.4	V
FG Amp Open Loop Gain	A_{FG}		45	60	-	dB
FG Amp Bias Voltage	V_{BFG}		2.2	2.5	2.8	V
FG Comparator Hysteresis	V_{FGhys}		40	110	160	mV

¹For input and output current specifications, negative current is defined as coming out of (sourcing) the specified device pin.

²Specifications throughout the allowed operating temperature range are guaranteed by design and characterization.

³Typical data are for initial design estimations only, and assume optimum manufacturing and application conditions. Performance may vary for individual units, within the specified maximum and minimum limits.

Logic States Table* (See timing charts, below)

Condition	HA	HB	HC	DIR	STOP	BRAKE	PWM	GHA	GLA	GHB	GLB	GHC	GLC	SA	SB	SC	
Forward	A	+	-	+	1	0	0	1	HI	LO	LO	HI	LO	LO	HI	LO	Z
	B	+	-	-	1	0	0	1	HI	LO	LO	LO	LO	HI	HI	Z	LO
	C	+	+	-	1	0	0	1	LO	LO	HI	LO	LO	HI	Z	HI	LO
	D	-	+	-	1	0	0	1	LO	HI	HI	LO	LO	LO	LO	HI	Z
	E	-	+	+	1	0	0	1	LO	HI	LO	LO	HI	LO	LO	Z	HI
	F	-	-	+	1	0	0	1	LO	LO	LO	HI	HI	LO	Z	LO	HI
Reverse	A	+	-	+	0	0	0	1	LO	HI	HI	LO	LO	LO	LO	HI	Z
	B	+	-	-	0	0	0	1	LO	HI	LO	LO	HI	LO	LO	Z	HI
	C	+	+	-	0	0	0	1	LO	LO	LO	HI	HI	LO	Z	LO	HI
	D	-	+	-	0	0	0	1	HI	LO	LO	HI	LO	LO	HI	LO	Z
	E	-	+	+	0	0	0	1	HI	LO	LO	LO	LO	HI	HI	Z	LO
	F	-	-	+	0	0	0	1	LO	LO	HI	LO	LO	HI	Z	HI	LO
Fault	-	-	-	X	X	X	X	LO	LO	LO	LO	LO	LO	Z	Z	Z	
	+	+	+	X	X	X	X	LO	LO	LO	LO	LO	LO	Z	Z	Z	
Brake	X	X	X	X	0	1	X	LO	HI	LO	HI	LO	HI	LO	LO	LO	
Coast	X	X	X	X	1	0	X	LO	LO	LO	LO	LO	LO	Z	Z	Z	
Standby	X	X	X	X	1	1	X	LO	LO	LO	LO	LO	LO	Z	Z	Z	

*X = Don't care (can be 1 or 0), Z = High impedance

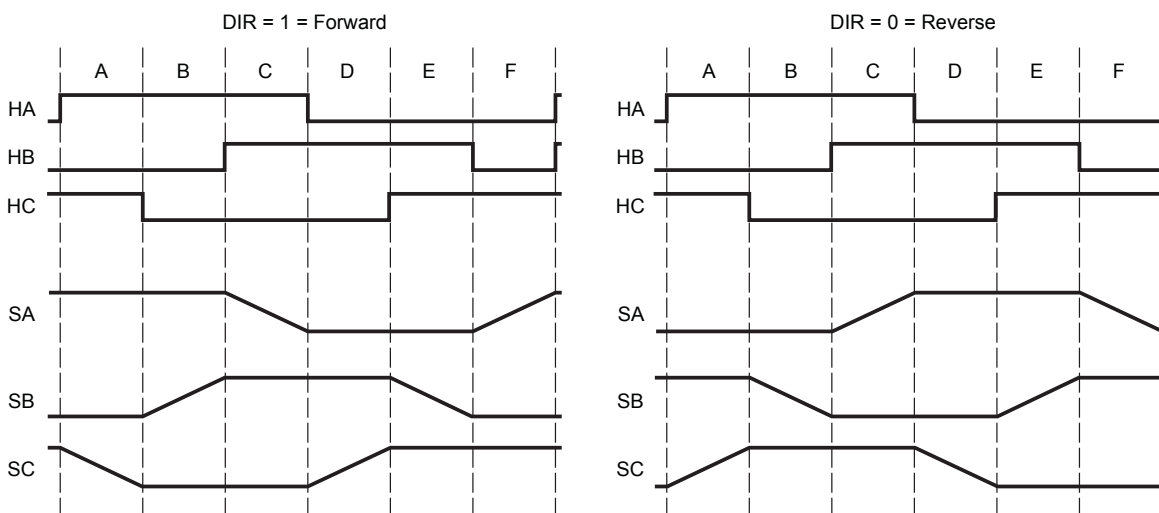

Power-Up and Standby Mode Timing Diagram

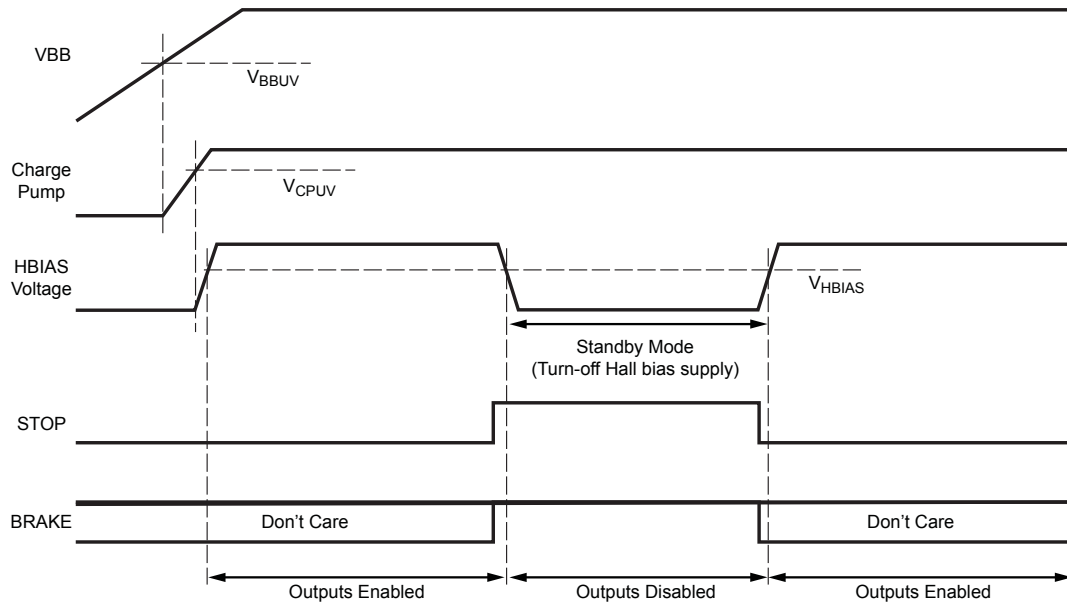

Power-Down Timing Diagram

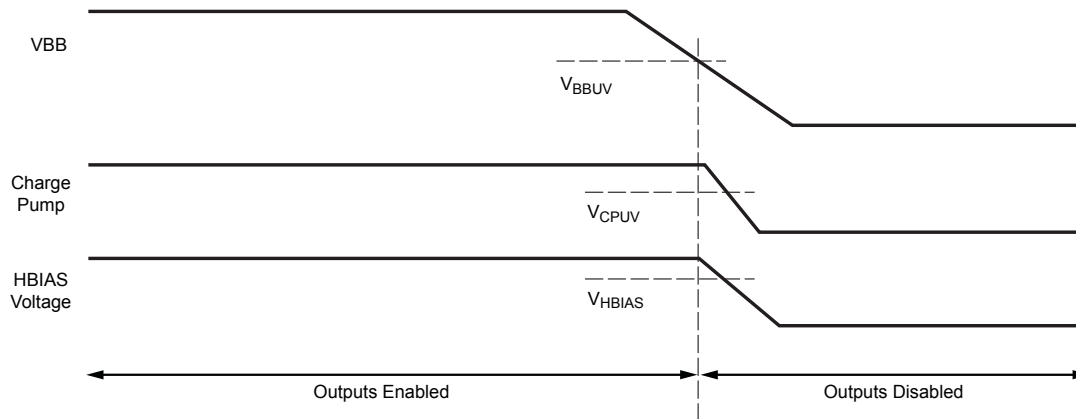

Functional Description

Current Regulation Load current is regulated by an internal fixed off-time PWM control circuit. When the outputs of the full bridge are turned on, current increases in the motor winding until it reaches a value, I_{TRIP} , given by:

$$I_{TRIP} = 200 \text{ mV} / R_{SENSE}$$

When I_{TRIP} is reached, the sense comparator resets the source enable latch, turning off the source driver. At this point, load inductance causes the current to recirculate for the fixed off-time period.

PWM Logic The PWM input terminal allows external PWM. PWM high turns on the selected sink-source pair. PWM low switches off the appropriate drivers and the load current decays. If PWM is held high, the current will rise until it reaches the level set by the internal current control circuit. Typically PWM frequency is in the 20 to 30 kHz range. The PWM logic is summarized in the following table:

PWM	Outputs	Outputs State
1	On	Drive
0	Source chopped	Slow decay with synchronous rectification

Fixed Off-Time The A4936 fixed off-time is set to 25 μs , nominal.

PWM Blank Timer When a source driver turns on, a current spike occurs due to the reverse recovery currents of the clamp diodes as well as switching transients related to distributed capacitance in the load. To prevent this current spike from erroneously resetting the source enable latch, the sense comparator is blanked. The blanking timer runs after the off-time counter completes, in order to provide the blanking function. The blanking timer is reset when PWM is low or DIR is changed. With external PWM control, a DIR change or a PWM-on triggers the blanking function. The duration is fixed at 1.5 μs .

Synchronous Rectification When a PWM-off cycle is triggered, either by a low input on PWM or by an internal fixed off-time cycle, load current recirculates. The A4936 synchronous rectification feature turns-on the appropriate MOSFETs during the current decay, and effectively shorts-out the body diodes with the low $R_{DS(on)}$ driver. This lowers power dissipation significantly and can eliminate the need for external Schottky diodes.

Run Mode The motor phases are only energized when the STOP input is low. When the STOP input is high, all MOSFETs are held in the off state and the phase connections to the motor are high impedance. In this state a running motor will coast to stop. The STOP input overrides the PWM input. When STOP is high and BRAKE is high, the A4936 enters Standby mode.

Brake Mode A logic high on the BRAKE pin activates Brake mode. A logic low allows normal operation. Braking turns on all three sink drivers, effectively shorting out the motor-generated BEMF. The BRAKE input overrides the PWM input and also the Lock Detect function. The STOP input must be low for Brake mode to operate.

It is important to note that the internal PWM current control circuit does not limit the current when braking, because the current does not flow through the sense resistor. The maximum current can be approximated by V_{BEMF} / R_{LOAD} . Care should be taken to insure that the maximum ratings of the A4396 are not exceeded in the worse case braking situation of high speed and high inertial load.

Standby Mode The reduced power Standby mode is provided to reduce current consumption when the motor is not required to be driven. The Hall bias supply and the charge pump are disabled and all MOSFETs are turned-off. The A4936 enters Standby mode when STOP and BRAKE are held high together. All other control inputs are ignored when in Standby mode.

HBIAS Function This provides a power supply of 7.5 V, current-limited to 30 mA. This reference voltage is used to power the logic sections of the A4936 and also to power the external Hall elements.

Charge Pump The internal charge pump is used to generate a supply above VBB to drive the high-side MOSFETs. The voltage on the VCP pin is internally monitored, and in case of a fault condition, the outputs of the device are disabled.

Fault Shutdown In the event of a fault due to excessive junction temperature or due to low voltage on VCP or VBB, the outputs of the device are disabled until the fault condition is removed. At power-up the UVLO circuit disables the drivers.

Overvoltage Protection VBB is monitored to determine if a hazardous voltage is present due to the motor generator pumping up the supply bus. When the voltage exceeds V_{BBOV} , the synchronous rectification feature is disabled.

Overtemperature Protection If die temperature exceeds approximately 165°C, the Thermal Shutdown function will disable the outputs until the internal temperature falls below the threshold, by the hysteresis.

Lock Detect Function The A4936 monitors the Hall inputs and the control inputs to determine if a locked rotor condition is present. A locked rotor is determined to be present under either of these two different conditions:

- The Hall inputs are not consistently changing.
- The proper commutation sequence is not being followed. The motor can be locked in a condition in which it toggles between two specific Hall device states.

If there are no Hall input changes within the lock time, t_{lock} , or the Hall inputs toggle between two adjacent states for longer than t_{lock} , then the outputs are disabled, and the fault is latched.

The fault remains latched until cleared by any one of the following actions:

- Rising or falling edge on the DIR pin.
- VBB UVLO threshold exceeded (during power-up cycle).
- PWM pin held low for $> t_{lock} / 2$.

The lock time, t_{lock} , is set by a capacitor connected to the CLD

pin. C_{LD} produces a triangle waveform (1.67 V peak-to-peak) with frequency linearly related to the capacitor value. t_{lock} is defined as 127 cycles of this triangle waveform, or:

$$t_{lock} = C_{LD} \times 20$$

where:

t_{lock} is the lock time in seconds, and

C_{LD} is the value of the capacitor in μF .

The Lock Detect function is disabled by connecting CLD to GND.

When BRAKE is high, lock detection is disabled. It also is disabled if the PWM input remains low for the duration of the Hall input lock detection.

FG Amplifier and Comparator A differential amplifier and a comparator are integrated into the A4936 to amplify and shape the FG signal from the FG coil underneath the motor. This coil is typically created with a copper PCB trace, and as the motor spins, the coil creates a low amplitude sinusoidal voltage with a frequency proportional to the motor speed.

The FG input differential amplifier is biased at 2.5 V, and the gain is set by the impedance between the FGFB pin and the FG- input. This amplified signal is then compared to 2.5 V to create the FGS output signal. The recommended value for the gain setting feedback resistor is 50 to 500 k Ω . The recommended value for the capacitor between FB+ and GND is 10 nF to 10 μF .

Package ET 32-Contact QFN

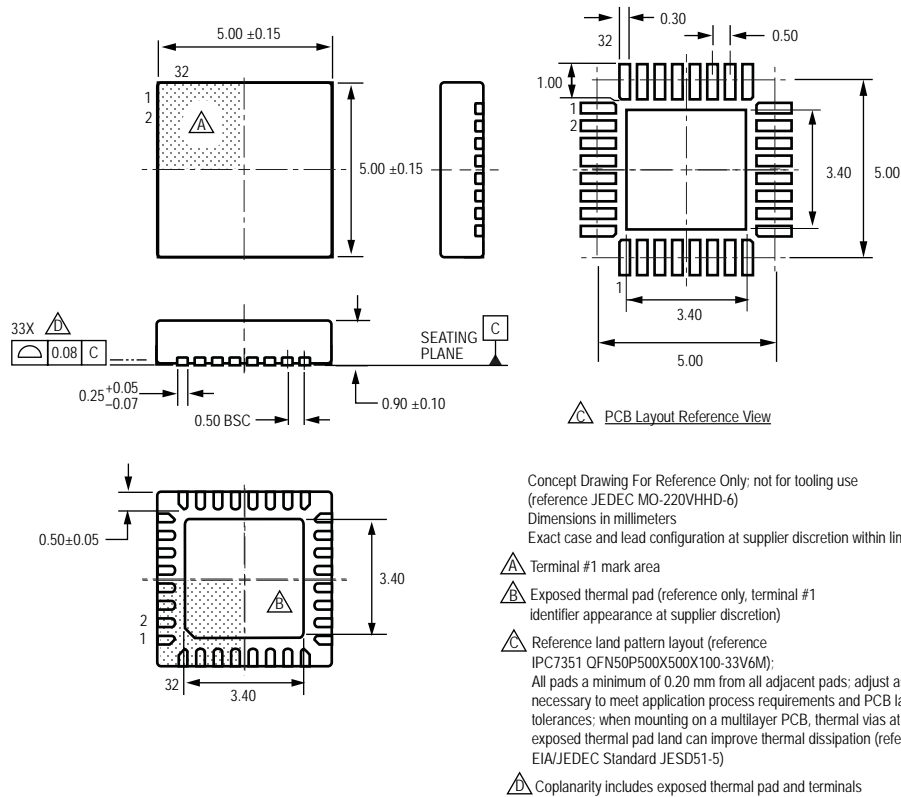

Copyright ©2010-2013, Allegro MicroSystems, LLC

Allegro MicroSystems, LLC reserves the right to make, from time to time, such departures from the detail specifications as may be required to permit improvements in the performance, reliability, or manufacturability of its products. Before placing an order, the user is cautioned to verify that the information being relied upon is current.

Allegro's products are not to be used in life support devices or systems, if a failure of an Allegro product can reasonably be expected to cause the failure of that life support device or system, or to affect the safety or effectiveness of that device or system.

The information included herein is believed to be accurate and reliable. However, Allegro MicroSystems, LLC assumes no responsibility for its use; nor for any infringement of patents or other rights of third parties which may result from its use.

For the latest version of this document, visit our website:

www.allegromicro.com

