

Apr.1.2017 Copyright 2017 HIROSE ELECTRIC CO., LTD. All Rights Reserved.

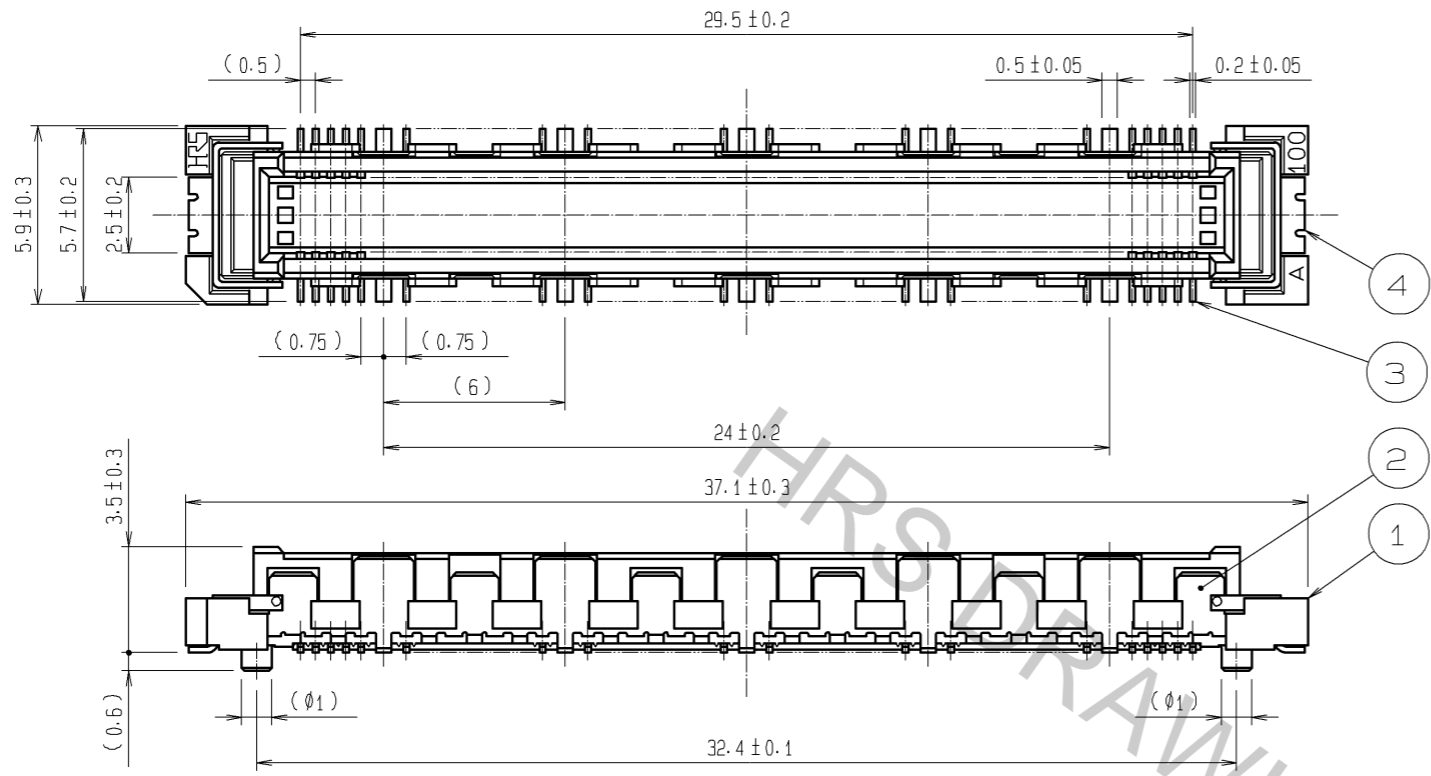

CROSS CUT SECTION - SIGNAL (5:1)

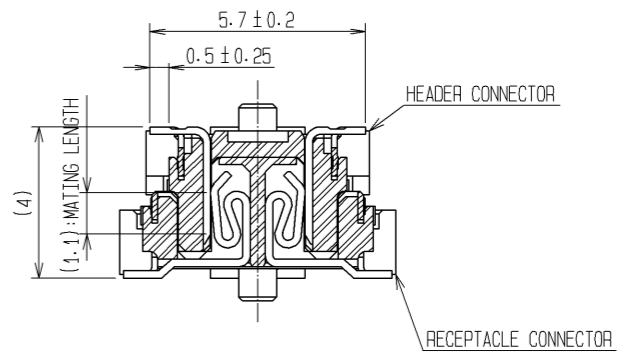

CROSS CUT SECTION - GROUND (5:1)

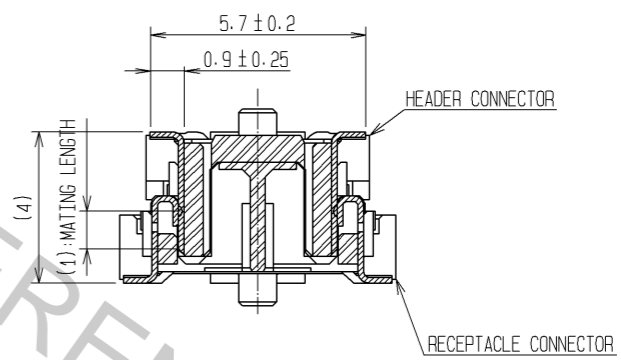

RECOMMENDED LAND PATTERN DIMENSION OF PCB
(RECOMMENDED METAL MASK THICKNESS: 0.15mm)

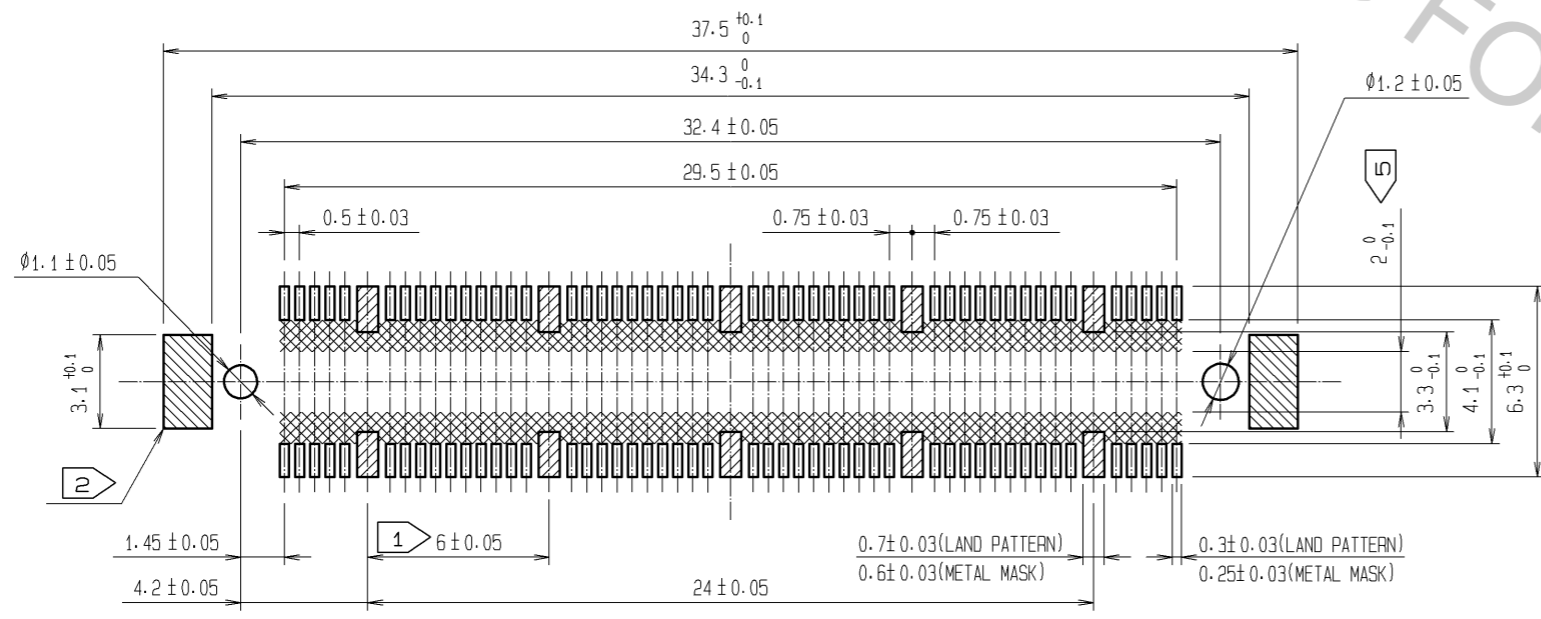

- NOTES
- ① 10 HATCHED PARTS: GROUND CIRCUIT.
 - ② 2 HATCHED PARTS: GROUND CIRCUIT.
 - ③ SMT LEAD-COPLANARITY: 0.1 MAX.
 - ④ THIS PRODUCT HAS NO POLARITY TO PATTERN FOR MOUNTING.
 - ⑤ MAKE SURE WIDTH OF PATTERN IS WITHIN THAT OF LAND, OR LEAD MAY TOUCH PATTERN. (THIS APPLIES TO HATCHED AREA.)
 - ⑥ THE DIMENSIONS IN PARENTHESES ARE FOR REFERENCE.

2	PHOSPHOR BRONZE	TIN-PLATING	4	PHOSPHOR BRONZE	TIN-PLATING			
1	LCP	BEIGE UL94V-0	3	PHOSPHOR BRONZE	CONTACT AREA: GOLD 0.1μm min. LEAD AREA: TIN-PLATING 1μm min. UNDER PLATING: NICKEL 1μm min.			
NO.	MATERIAL	FINISH	REMARKS	NO.	MATERIAL	FINISH	REMARKS	
UNITS		SCALE	COUNT	DESCRIPTION OF REVISIONS		DESIGNED	CHECKED	DATE
mm		4 : 1	1	DIS-F-006362		Y.J. ASAO	HT. YAMAGUCHI	12.08.29
HRS HIROSE ELECTRIC CO., LTD.		APPROVED: HS. OKAWA	05.09.03	DRAWING NO.		EDC3-151945-25		
		CHECKED: HS. OZAWA	05.09.02	PART NO.		FX10A-100P/10-SV(71)		
		DESIGNED: TH. NODA	05.09.02	CODE NO.		CL570-0002-8-71		
		DRAWN: TH. NODA	05.09.02					