

# MAX7360 Evaluation Kit

## Evaluates: MAX7360

### General Description

The MAX7360 evaluation kit (EV kit) provides a proven design to evaluate the MAX7360 I<sup>2</sup>C-interfaced low-EMI key-switch controller and 8 LED drivers/GPIO with integrated ESD protection. The EV kit also includes Windows® 2000-, Windows XP®, and Windows Vista®-compatible software that provides a simple graphical user interface (GUI) for exercising the features of the MAX7360.

The MAX7360 EV kit PCB comes with a MAX7360EWX+ installed.

*Windows, Windows XP, and Windows Vista are registered trademarks of Microsoft Corp.*

### Features

- ◆ **Wide 1.6V to 3.3V Supply Range**
- ◆ **36-Bump WLP Package**
- ◆ **Windows 2000-, Windows XP-, and Windows Vista (32-Bit)-Compatible Software**
- ◆ **USB-PC Connection (Cable Included)**
- ◆ **USB Powered**
- ◆ **Lead(Pb)-Free and RoHS Compliant**
- ◆ **Optional GPO Output LEDs (COL2–COL7)**
- ◆ **RGB LED Output (PORT1, PORT2, PORT3)**
- ◆ **White LEDs (PORT0) (Requires External VH Supply)**
- ◆ **LED Output (PORT4)**
- ◆ **Rotary Encoder (PORT6, PORT7)**
- ◆ **I<sup>2</sup>C Interface Terminals**
- ◆ **Proven PCB Layout**
- ◆ **Fully Assembled and Tested**

### Ordering Information

PART	TYPE
MAX7360EVKIT+	EV Kit

+Denotes lead(Pb)-free and RoHS compliant.

### Component List

DESIGNATION	QTY	DESCRIPTION
C1, C5–C9, C12, C17, C18, C37	10	0.1µF ±10%, 16V X7R ceramic capacitors (0603) Murata GRM188R71C104K
C2	0	Not installed, ceramic capacitor (0603)
C3, C13	0	Not installed, ceramic capacitors (1206)
C4	1	0.033µF ±10%, 25V X7R ceramic capacitor (0603) Murata GRM188R71E333K
C10, C39	2	1µF ±10%, 16V X5R ceramic capacitors (0603) TDK C1608X5R1C105K
C11, C38, C40	3	10µF ±20%, 16V X5R ceramic capacitors (1206) Murata GRM31CR61C106M

DESIGNATION	QTY	DESCRIPTION
C15, C16	2	10pF ±5%, 50V C0G ceramic capacitors (0603) TDK C1608C0G1H100J
C30, C31	2	22pF ±5%, 50V C0G ceramic capacitors (0603) TDK C1608C0G1H220J
H1, H2	2	20-pin headers
J1	1	USB type-B right-angle female receptacle
J3	0	Not installed, dual-row (2 x 5) 10-pin header
JU1	1	Dual-row (2 x 4) 8-pin header
JU2, JU9, JU15, JU16	4	3-pin headers
JU10–JU14, JU24, JU25	0	Not installed, headers—short (PC trace)

**For pricing, delivery, and ordering information, please contact Maxim Direct at 1-888-629-4642, or visit Maxim's website at [www.maximintegrated.com](http://www.maximintegrated.com).**

# MAX7360 Evaluation Kit

## Evaluates: MAX7360

### Component List (continued)

DESIGNATION	QTY	DESCRIPTION
JU3–JU8, JU17–JU23	13	2-pin headers
KEY0–KEY63, SW1	65	Momentary, normally open switches
L1	1	Ferrite bead (0603) TDK MMZ1608R301A
LED1, LED6–LED15	11	Red LEDs (0805)
LED2, LED3, LED4	3	White LEDs (PLCC2)
LED5	1	RGB LED (PLCC4)
R1, R2	2	27 $\Omega$ $\pm$ 5% resistors (0603)
R3	1	1.5k $\Omega$ $\pm$ 5% resistor (0603)
R4	1	470 $\Omega$ $\pm$ 5% resistor (0603)
R5, R18	2	2.2k $\Omega$ $\pm$ 5% resistors (0603)
R6, R26–R29	5	10k $\Omega$ $\pm$ 5% resistors (0603)
R7, R8	2	4.7k $\Omega$ $\pm$ 5% resistors (0603)
R9, R25	2	33k $\Omega$ $\pm$ 5% resistors (0603)
R10–R17, R24	9	330 $\Omega$ $\pm$ 5% resistors (0603)
R19–R23	0	Not installed, resistors—short (PC trace) (0402)
RE67	1	Rotary encoder
U1	1	I <sup>2</sup> C-interfaced low-EMI key- switch controller (36 WLP) Maxim MAX7360EWX+

DESIGNATION	QTY	DESCRIPTION
U2	1	2.5V regulator (5 SC70) Maxim MAX8511EXK25+T (Top Mark: ADV)
U3	1	3.3V regulator (5 SC70) Maxim MAX8511EXK33+T (Top Mark: AEI)
U4	1	Low-power microcontroller (68 QFN-EP*) Maxim MAXQ2000-RAX+
U5	1	UART-to-USB converter (32 TQFP)
U6	1	93C46 type 3-wire EEPROM 16-bit architecture (8 SO)
Y2	1	16MHz crystal Hong Kong X'tals SSM16000N1HK188F0-0
Y3	0	Not installed, crystal (CMR200T)
Y4	1	6MHz crystal Hong Kong X'tals SSL60000N1HK188F0-0
—	18	Shunts
—	1	USB high-speed A-to-B cables, 6ft
—	1	PCB: MAX7360 EVALUATION KIT+

\*EP = Exposed pad.

### Component Suppliers

SUPPLIER	PHONE	WEBSITE
Hong Kong X'tals Ltd.	852-35112388	www.hongkongcrystal.com
Murata Electronics North America, Inc.	770-436-1300	www.murata-northamerica.com
TDK Corp.	847-803-6100	www.component.tdk.com

**Note:** Indicate that you are using the MAX7360 when contacting these component suppliers.

### MAX7360 EV Kit Files

FILE	DESCRIPTION
MAX7360.EXE	Application program
FTD2XX.INF	USB device driver file
USB_Driver_Help.PDF	USB driver installation help file

# MAX7360 Evaluation Kit

## Evaluates: MAX7360

### Quick Start

#### Required Equipment

- MAX7360 EV kit (USB cable included)
- User-supplied Windows 2000, Windows XP, or Windows Vista PC with a spare USB port
- External 14V at 250mA DC power supply (required only if driving white LEDs)

**Note:** In the following sections, software-related items are identified by bolding. Text in **bold** refers to items directly from the EV kit software. Text in **bold and underlined** refers to items from the Windows operating system.

#### Procedure

The MAX7360 EV kit is fully assembled and tested. Follow the steps below to verify board operation:

- 1) Visit [www.maximintegrated.com/evkitsoftware](http://www.maximintegrated.com/evkitsoftware) to download the latest version of the EV kit software, 7360Rxx.ZIP. Save the EV kit software to a temporary folder and uncompress the ZIP file.
- 2) Install the EV kit software on your computer by running the INSTALL.EXE program inside the temporary folder. The program files are copied and icons are created in the Windows **Start | Programs** menu.
- 3) Verify that all jumpers (JU1–JU25) are in their default positions, as shown in Table 1.
- 4) Connect the USB cable from the PC to the EV kit board. A **New Hardware Found** window pops up when installing the USB driver for the first time. If a window is not seen that is similar to the one described above after 30s, remove the USB cable from the board and reconnect it. Administrator privileges are required to install the USB device driver on Windows.
- 5) Follow the directions of the **Add New Hardware Wizard** to install the USB device driver. Choose the **Search for the best driver for your device** option. Specify the location of the device driver to be **C:\Program Files\MAX7360** (default installation directory) using the **Browse** button. During device driver installation, Windows may show a warning message indicating that the device driver Maxim uses does not contain a digital signature. This is not an error condition and it is safe to proceed with installation. Refer to the USB\_Driver\_Help.PDF document included with the software for additional information.
- 6) Verify that the EV kit's LED13 is lit, indicating that the USB is connected and providing power.
- 7) Start the MAX7360 EV kit software by opening its icon in the **Start | Programs** menu. The EV kit software main window appears, as shown in Figure 1.
- 8) The software automatically connects to the board after a few seconds.
- 9) Press the **Initialize EV kit** button to configure default settings for demonstration.
- 10) *Keyscan Demonstration:* On the EV kit board, press buttons in the KEY0–KEY63 matrix. Verify that the keyscan codes are reported in the software's history window after five to six keypress events are queued, depending on the debounce time and interrupt register settings. The most recent scan code is identified in the **Key Grid**.
- 11) *Rotary Encoder Demonstration:* Select the software's **Port Configuration** tab (Figure 2), and then turn the EV kit's rotary encoder (RE67). Interrupt  $\overline{\text{INTI}}$  triggers the software to read the shaft encoder delta, which is accumulated and reported by the software. (**Note:** The mechanical detents on the shaft encoder only approximate the actual encoding positions.)
- 12) *Port Input Demonstration:* On the EV kit, press and hold SW1, then in the software's **Port Configuration** tab, under **0x49 GPIO Port Status**, press the **Read** button. Verify that **Port5** is unchecked, indicating that the PORT5 pin is logic-low (due to SW1 being closed).
- 13) Release SW1, and interrupt pin  $\overline{\text{INTI}}$  triggers the software to read **0x49 GPIO Port Status** again. **Port5** is now checked, indicating that the PORT5 pin is now logic-high.
- 14) Move JU9 to the 2-3 position, powering the PORT0–PORT4 LEDs from the USB. LED6 (PORT4) should be dimly lit.
- 15) In the software's **PWM Intensity** tab (Figure 3), set **0x54 Port P4 PWM Intensity** to 100 and press the **Write** button. LED6 should now be brightly lit.
- 16) In the software's **PWM Configuration** tab (Figure 4), set **0x5C Port P4 Configuration** to select **Blink Period** of **010 512ms**, and press the **Write** button. After a moment, LED6 will blink on and off.
- 17) *Port Output RGB Color LED Demonstration:* Select the software's **PWM Intensity** tab and press the **Pick RGB Color (P1=Red,P2=Green,P3=Blue)** button. The standard Windows color picker dialog box appears. Select a color and press **OK**. The selected RGB value is written to the PWM intensity registers of PORT1, PORT2, and PORT3.

# MAX7360 Evaluation Kit

## Evaluates: MAX7360

- 18) *Port Output White LED Demonstration* (**Warning: Use eye protection when working with high-brightness LEDs**): Connect an external 14V DC power supply between EXT VH and GND. Move JU9 to the 1-2 position, powering the PORT0–PORT4 LEDs from EXT VH.
- 19) Move JU16 to the 2-3 position, connecting PORT0 to series-connected white LEDs LED2, LED3, and LED4.
- 20) In the software's **PWM Intensity** tab, set **0x50 Port P0 PWM Intensity** to **255** and press the **Write** button.
- 21) In the software's **Port Configuration** tab, set **0x43 GPIO Constant Current** value of **Constant Current** to **11: 20mA**. The white LEDs are now blinking brightly at 50% duty cycle.
- 22) In the software's **PWM Configuration** tab, set **0x58 Port P0 Configuration** value of **Blink Period** to **000 no blinking** and press the **Write** button. The white LEDs are now steady on.

### **Detailed Description of Software**

The main window of the evaluation software (Figure 1) provides direct access to all registers and controls the interrupt response. The software automatically searches for the MAX7360 EV kit hardware when launched. Once the hardware is found and connected, the I<sup>2</sup>C **Device Address** is shown in the lower-left corner.

#### **Auto Read**

The software automatically reads registers every 250ms if the **Auto Read all** checkbox is checked. This rate can be adjusted through the **Options | Polling Rate** menu item.

#### **Registers**

Each of the MAX7360 registers is represented on the software's main window (Figures 1–4). Each register has its own **Read** and **Write** buttons. Pressing the **Read entire FIFO now** button reads register 0x00 repeatedly until the FIFO indicates that all keypress events have been read.

#### **Key Grid**

Whenever a keypress event is received, the key location is shown on the **Key Grid**. This grid shows eight rows and eight columns. Register **0x02 Debounce / Port Enable** determines how many of the column pins are taken away from the **Key Grid** and is used for general-purpose outputs (GPOs).

#### **Interrupt Response**

Although the PC software cannot respond to interrupts with the speed of a true low-level hardware interrupt, the software does offer flexibility for evaluation. The software polls the status of the INTK and INTI output pins twice every second. The **Periodic Actions** checkboxes determine what action the software takes when an interrupt is active.

#### **History Window**

Each register read or write event is recorded in a scrollable text window underneath the interrupt handler actions.

#### **Using LED12–LED7 as GPO Indicators**

To configure the COL7 pin as an open-drain GPO, first change the keyscan partition by changing the value of the **0x02 Debounce / Port Enable** register to **Output Ports GPO7 / Scan COL6 - COL0**. Next, press its **Write** button. Finally, connect LED12 to the COL7 pin by installing a shunt at JU8. To drive COL7 low, illuminating the LED, set the value of the **0x04 Ports** register so that the **GPO7** checkbox is unchecked, and press its **Write** button.

To configure additional COL pins as open-drain GPOs, the procedure is similar. Write the **0x02 Debounce / Port Enable** register to select how many of the COL pins will be used for keyscanning and how many for output ports. Keyscanning always uses the lowest numbered COL pins. Set the JU3–JU8 jumpers to enable the LED outputs as needed. Write the port data into the **0x04 Ports** register (unchecked = output low, checked = output undriven). See the MAX7360 IC data sheet for more information about the ports register.

To configure the INTK pin for use as a GPO pin, set both the **FIFO Level** and **Time** combo box of register **0x03 Interrupt** to **Not Used**, then press the **Write** button. When configured for GPO, the INTK pin is controlled from the **0x04 Ports** register (Figure 1).

#### **Advanced User Interface**

A serial interface can be used by advanced users by selecting the **Options | Interface (Advanced Users)** menu item.

For I<sup>2</sup>C, click on the **2-wire interface** tab shown in Figure 5. Press the **Hunt for active listeners** button to obtain the current MAX7360 slave address in the **Target Device Address** combo box. In the **General commands** tab select **1 - SMBusWriteByte(addr,cmd,data8)** in the **Command** drop-down list. Enter the desired values into the **Command byte** and **Data Out** combo boxes and then press the **Execute** button.

# MAX7360 Evaluation Kit

## Evaluates: MAX7360

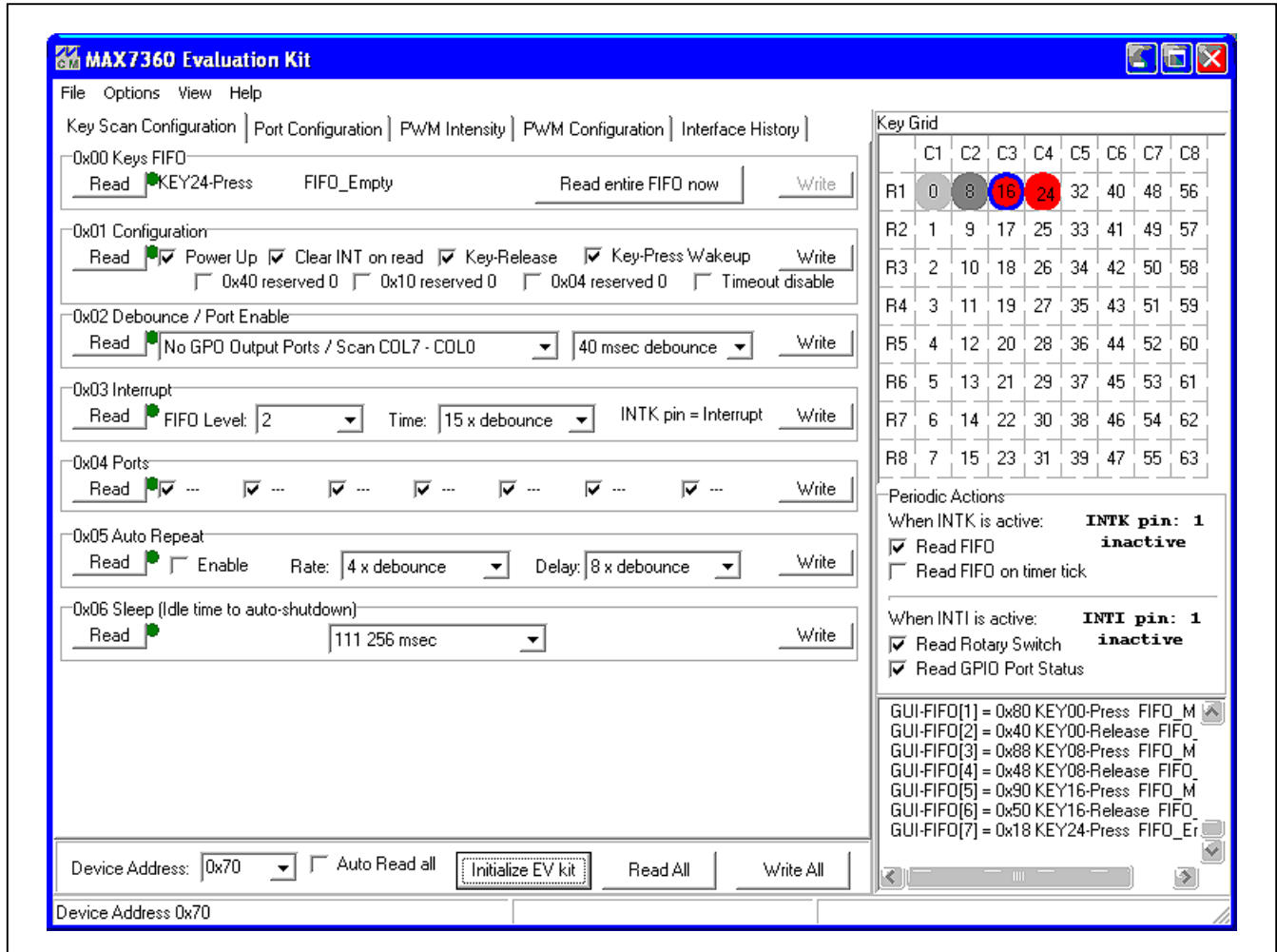

Figure 1. MAX7360 EV Kit Software Main Window (Keyscan ConfigurationTab)

# MAX7360 Evaluation Kit

## Evaluates: MAX7360

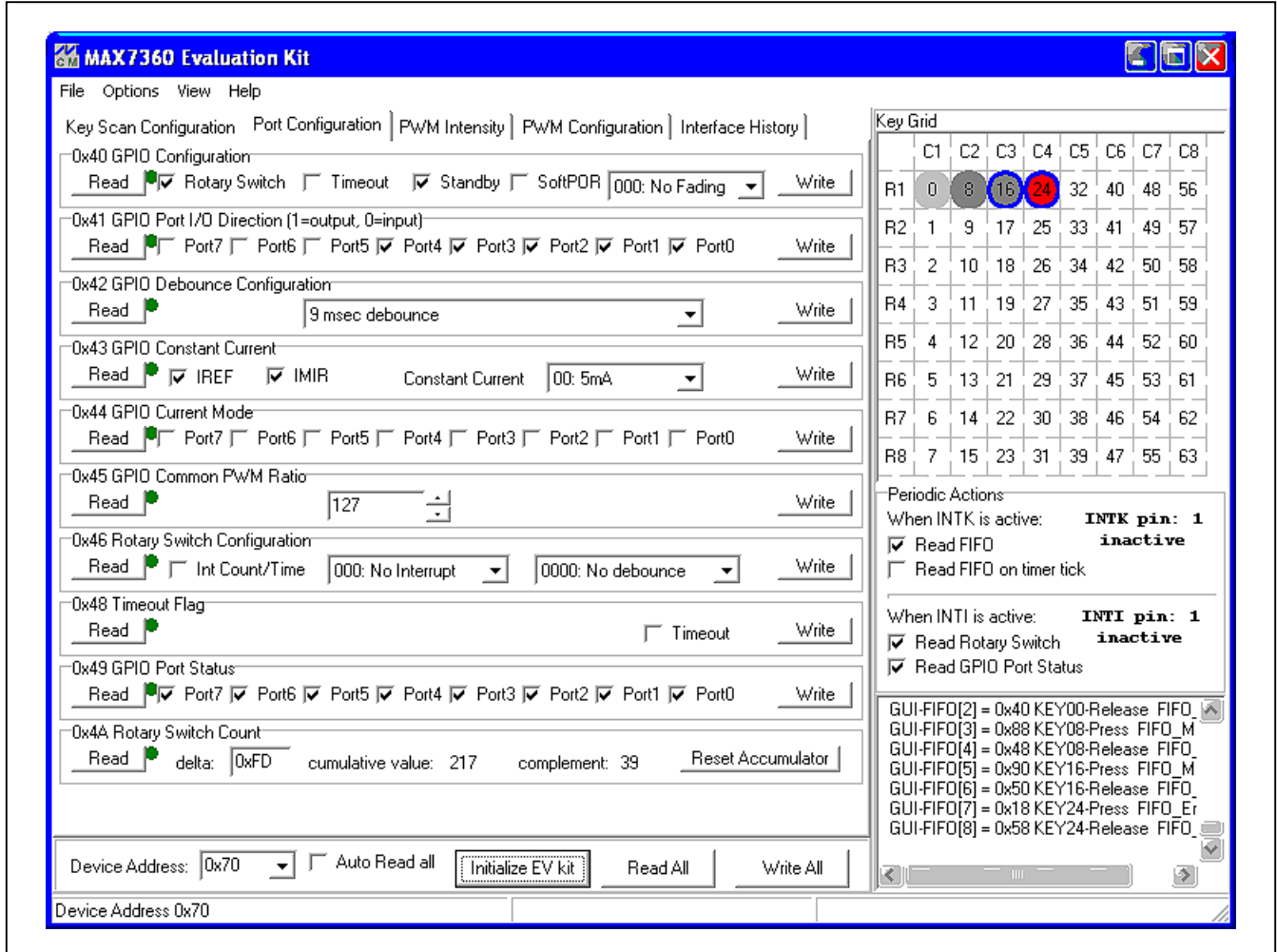

Figure 2. MAX7360 EV Kit Software Main Window (Port Configuration Tab)

# MAX7360 Evaluation Kit

## Evaluates: MAX7360

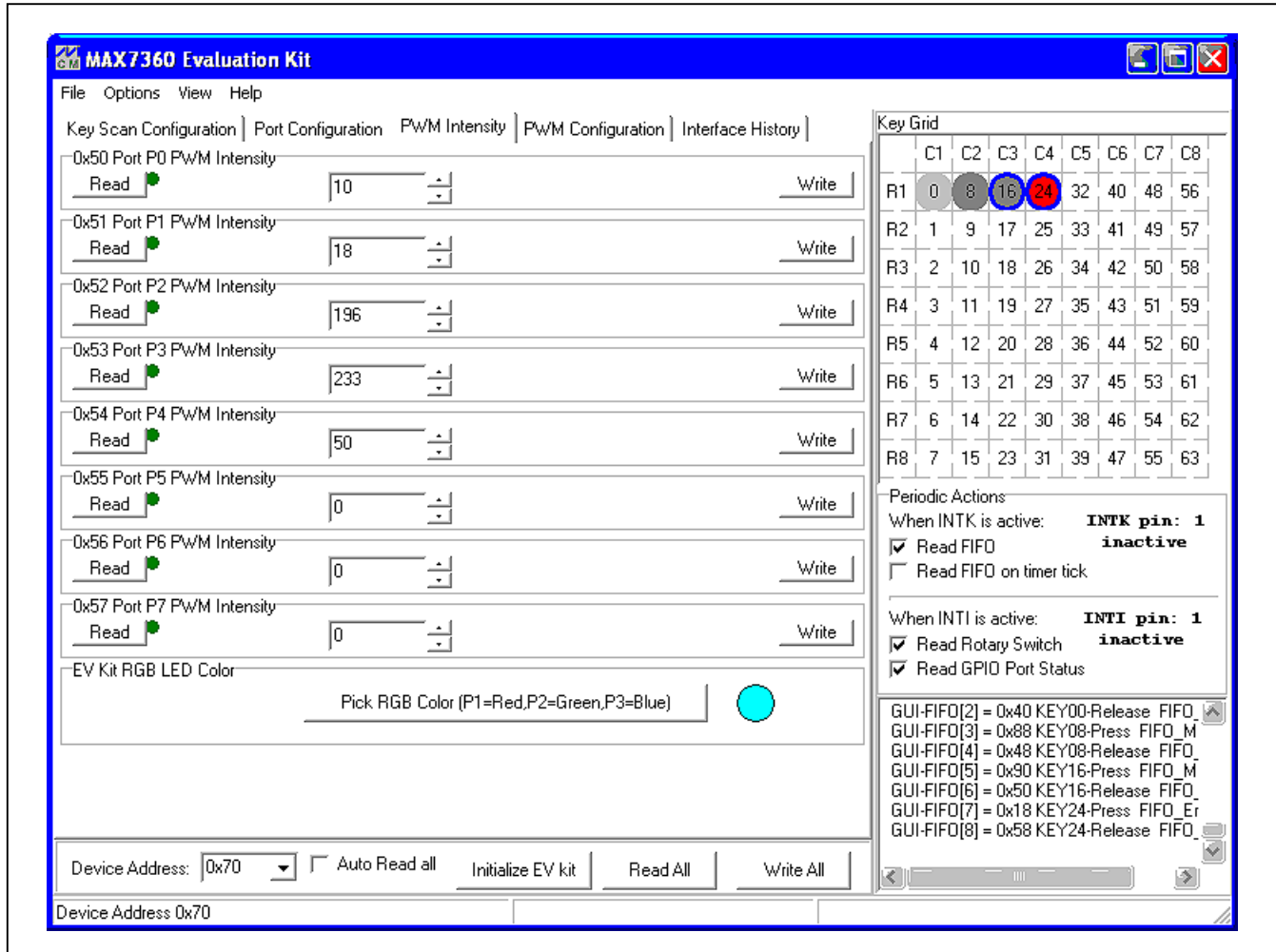

Figure 3. MAX7360 EV Kit Software Main Window (PWM Intensity Tab)

# MAX7360 Evaluation Kit

## Evaluates: MAX7360

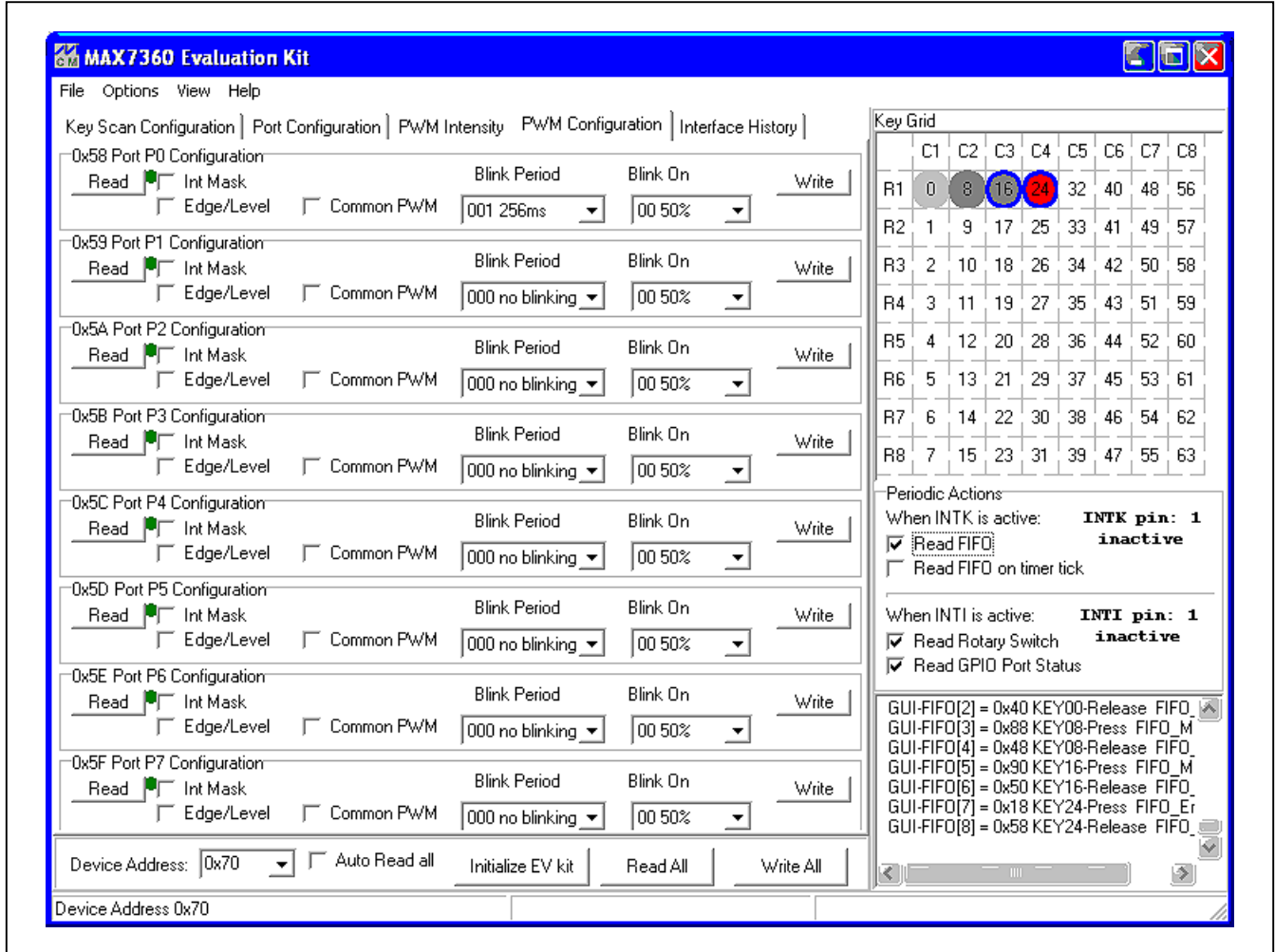

Figure 4. MAX7360 EV Kit Software Main Window (PWM Configuration Tab)



# MAX7360 Evaluation Kit

## Evaluates: MAX7360

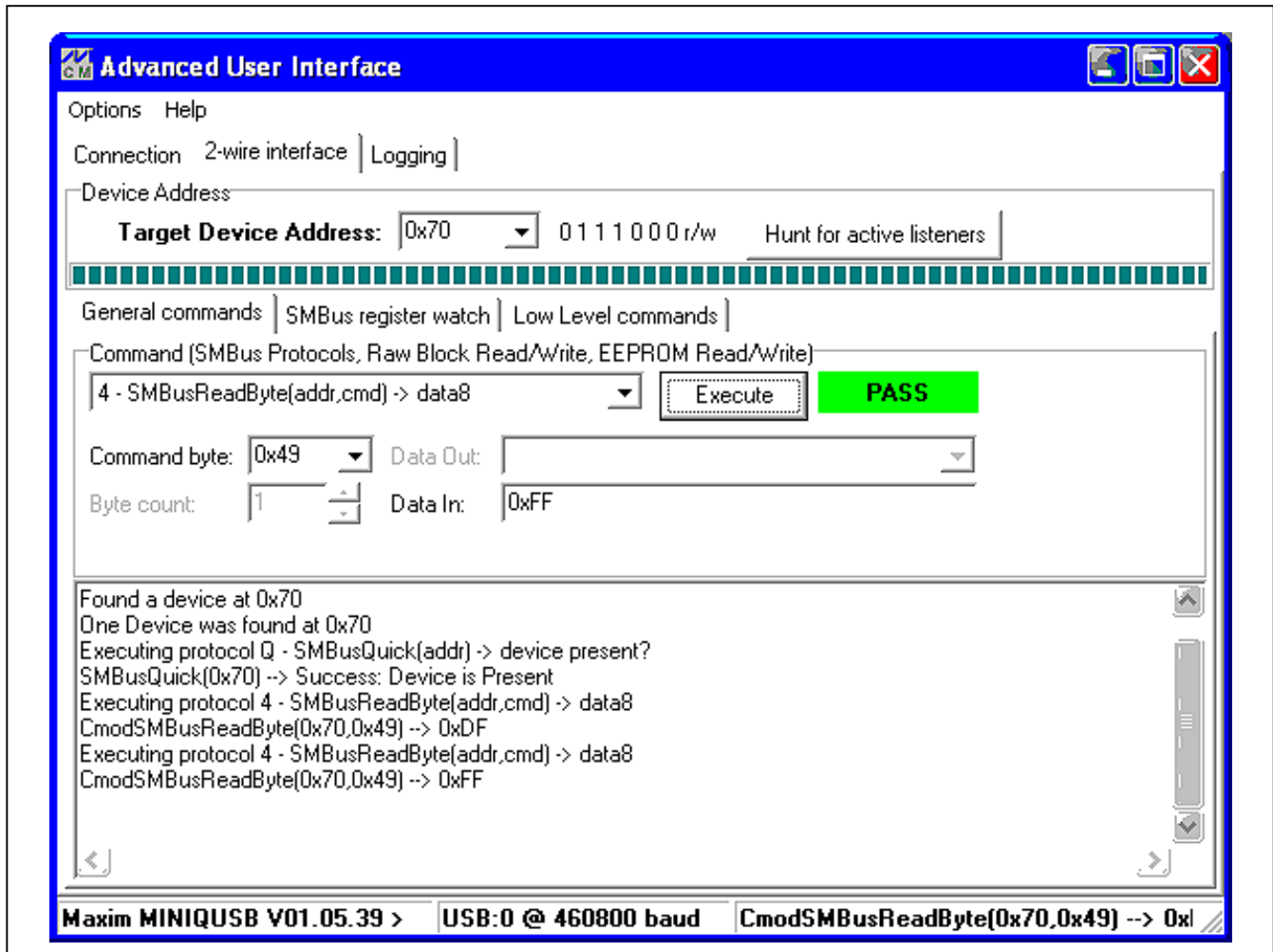

Figure 5. Advanced User Interface Window (2-Wire Interface Tab)

# MAX7360 Evaluation Kit

## Evaluates: MAX7360

### Detailed Description of Hardware

The MAX7360 EV kit provides a proven layout for the MAX7360. An easy-to-use USB-PC connection is included on the EV kit.

The MAX7360 (U1) scans a matrix of keys (KEY0–KEY63). The EV kit provides an 8 x 8 matrix of keys. To demonstrate GPO capability, LED indicators are jumper selectable for COL2–COL7. The FTDI FT232BL (U5) provides the USB engine. The USB 5V power is regulated down to 2.5V by U2. LED13 indicates that USB 5V power is present. The low-voltage RISC microcontroller, MAXQ2000 (U4), processes commands sent by a pro-

gram running on the PC. The firmware loaded on this board is identical to the MINIQUSB interface module.

### **Using an External I<sup>2</sup>C Bus Instead of USB**

To disconnect from the on-board I<sup>2</sup>C bus, cut the links on the back of the PCB at jumper locations JU10 and JU11. If the external I<sup>2</sup>C bus already has appropriate pullup resistors, cut the links at jumper locations JU12 and JU13. Leave the USB connector (J1) unconnected. Move the JU2 shunt to pins 2-3, and provide 2.5V to 3.6V power to the GND and EXT VCC oval pads. Connect the external I<sup>2</sup>C bus to the SCL and SDA test points of header H2.

**Table 1. MAX7360 EV Kit Jumper Descriptions (JU1–JU25)**

JUMPER	SIGNAL	SHUNT POSITION	DESCRIPTION
JU1	AD0	1-2*	AD0 = GND, selecting I <sup>2</sup> C address 0x70
		3-4	AD0 = SCL, selecting I <sup>2</sup> C address 0x74
		5-6	AD0 = VCC, selecting I <sup>2</sup> C address 0x78
		7-8	AD0 = SDA, selecting I <sup>2</sup> C address 0x7C
JU2	VCC	1-2*	Power VCC from 3.3V LDO
		2-3	Power VCC from external user-supplied power supply
JU3	GPO2	1-2	COL2 drives GPO2 LED
		Open*	COL2 connects to key matrix
JU4	GPO3	1-2	COL3 drives GPO3 LED
		Open*	COL3 connects to key matrix
JU5	GPO4	1-2	COL4 drives GPO4 LED
		Open*	COL4 connects to key matrix
JU6	GPO5	1-2	COL5 drives GPO5 LED
		Open*	COL5 connects to key matrix
JU7	GPO6	1-2	COL6 drives GPO6 LED
		Open*	COL6 connects to key matrix
JU8	GPO7	1-2	COL7 drives GPO7 LED
		Open*	COL7 connects to key matrix
JU9	VH	1-2*	Power VH from external user-supplied power supply (VH < 14V)
		2-3	Power VH from USB+5V supply
JU10	SDA	PCB trace shorted*	SDA connected to on-board I <sup>2</sup> C bus
		PCB trace cut open	SDA must be connected to an external I <sup>2</sup> C bus
JU11	SCL	PCB trace shorted*	SCL connected to on-board I <sup>2</sup> C bus
		PCB trace cut open	SCL must be connected to an external I <sup>2</sup> C bus
JU12	SDA	PCB trace shorted*	SDA connected to on-board pullup resistor
		PCB trace cut open	SDA pullup resistor must be provided externally

# MAX7360 Evaluation Kit

## Evaluates: MAX7360

**Table 1. MAX7360 EV Kit Jumper Descriptions (JU1–JU25) (continued)**

JUMPER	SIGNAL	SHUNT POSITION	DESCRIPTION
JU13	SCL	PCB trace shorted*	SCL connected to on-board pullup resistor
		PCB trace cut open	SCL pullup resistor must be provided externally
JU14	TEST	PCB trace shorted*	U1 pin A1 is connected to GND
		PCB trace cut open	U1 pin A1 is not connected
JU15	VLED	1-2*	Power GPO2–GPO7 LEDs from 3.3V LDO
		2-3	Power GPO2–GPO7 LEDs from external user-supplied 3.3V power supply
JU16	PORT0	1-2*	PORT0 drives single red LED
		2-3	PORT0 drives 3 series-connected white LEDs (requires VH = 14V)
		Open	PORT0 unconnected
JU17	PORT5	1-2*	PORT5 is pulled high by 2.2kΩ resistor, and pulled low by momentary switch SW1
		Open	PORT5 not connected unless momentary switch SW1 is pressed
JU18	PORT1	1-2*	PORT1 drives red channel of RGB color LED
		Open	PORT1 unconnected
JU19	PORT2	1-2*	PORT2 drives green channel of RGB color LED
		Open	PORT2 unconnected
JU20	PORT3	1-2*	PORT3 drives blue channel of RGB color LED
		Open	PORT3 unconnected
JU21	PORT4	1-2*	PORT4 drives single red LED
		Open	PORT4 unconnected
JU22	PORT6	1-2*	PORT6 connects to rotary encoder RE67
		Open	PORT6 unconnected
JU23	PORT7	1-2*	PORT7 connects to rotary encoder RE67
		Open	PORT7 unconnected
JU24	$\overline{\text{INTI}}$	PCB trace shorted*	$\overline{\text{INTI}}$ connected to MINIQUSB GPIO K1 input
		PCB trace cut open	$\overline{\text{INTI}}$ not connected to MINIQUSB
JU25	$\overline{\text{INTK}}$	PCB trace shorted*	$\overline{\text{INTK}}$ connected to MINIQUSB GPIO K6 input
		PCB trace cut open	$\overline{\text{INTK}}$ not connected to MINIQUSB

\*Default position.



# MAX7360 Evaluation Kit

## Evaluates: MAX7360

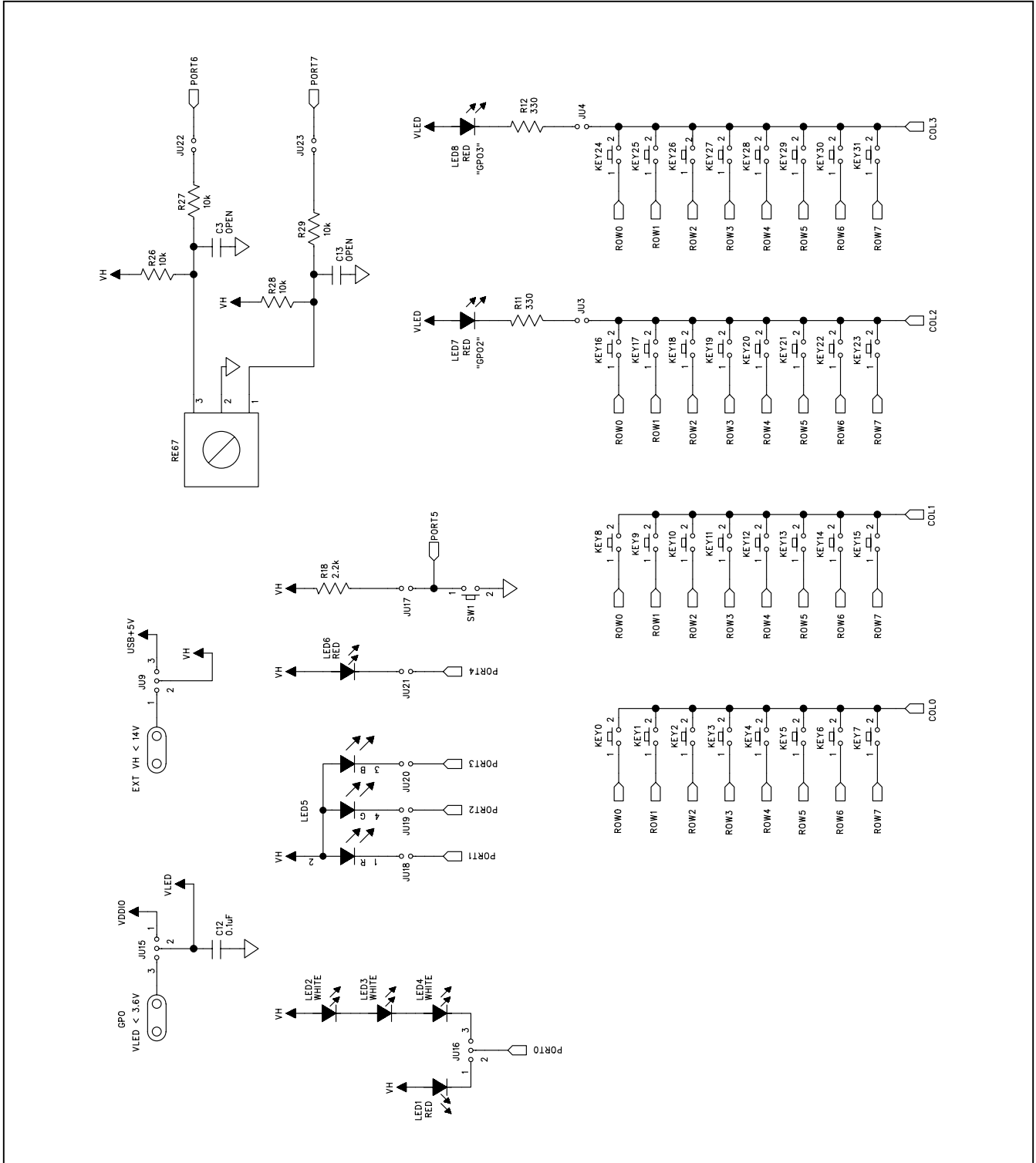

Figure 6b. MAX7360 EV Kit Schematic (Sheet 2 of 5)

# MAX7360 Evaluation Kit

## Evaluates: MAX7360

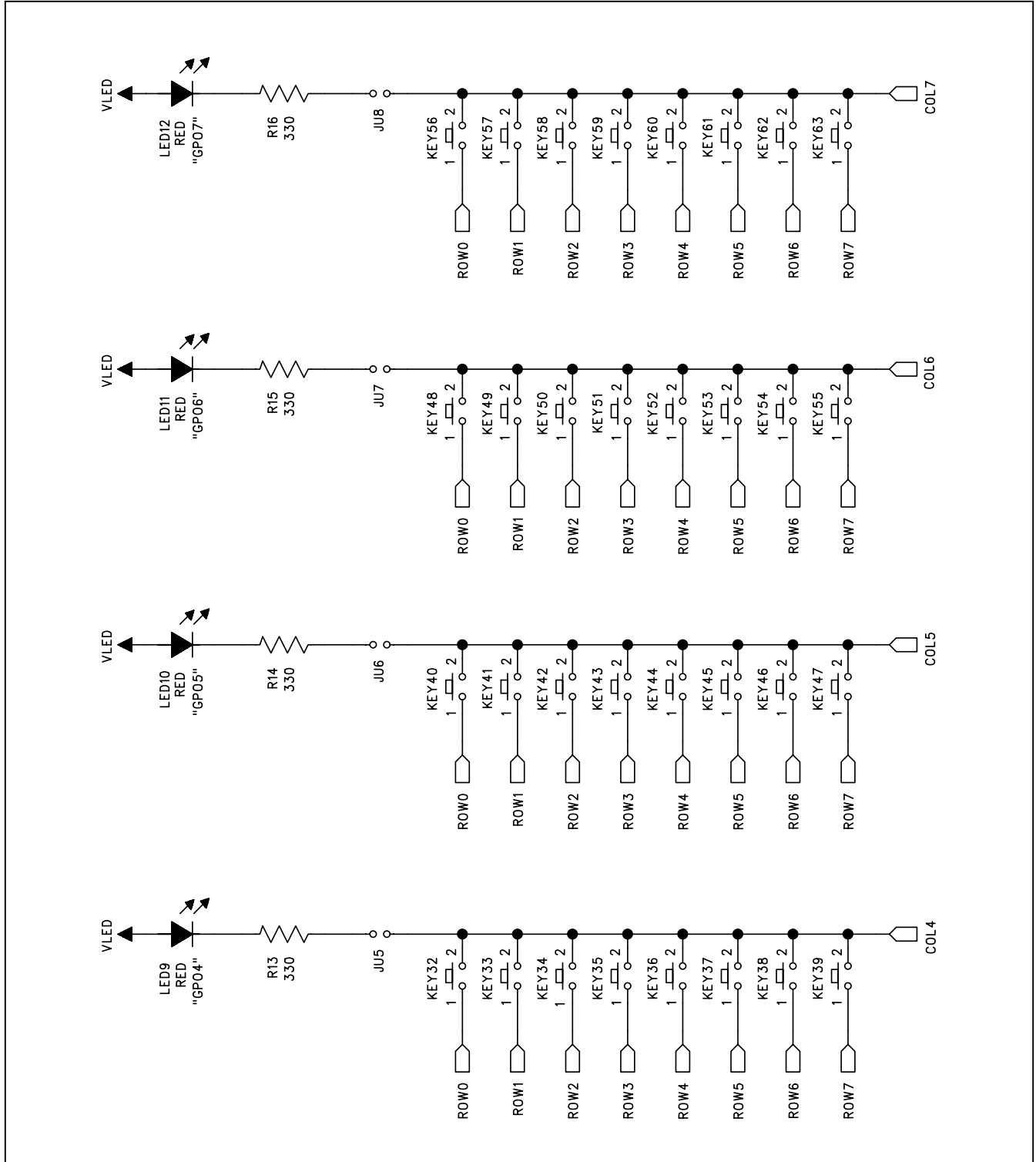

Figure 6c. MAX7360 EV Kit Schematic (Sheet 3 of 5)

# MAX7360 Evaluation Kit

## Evaluates: MAX7360

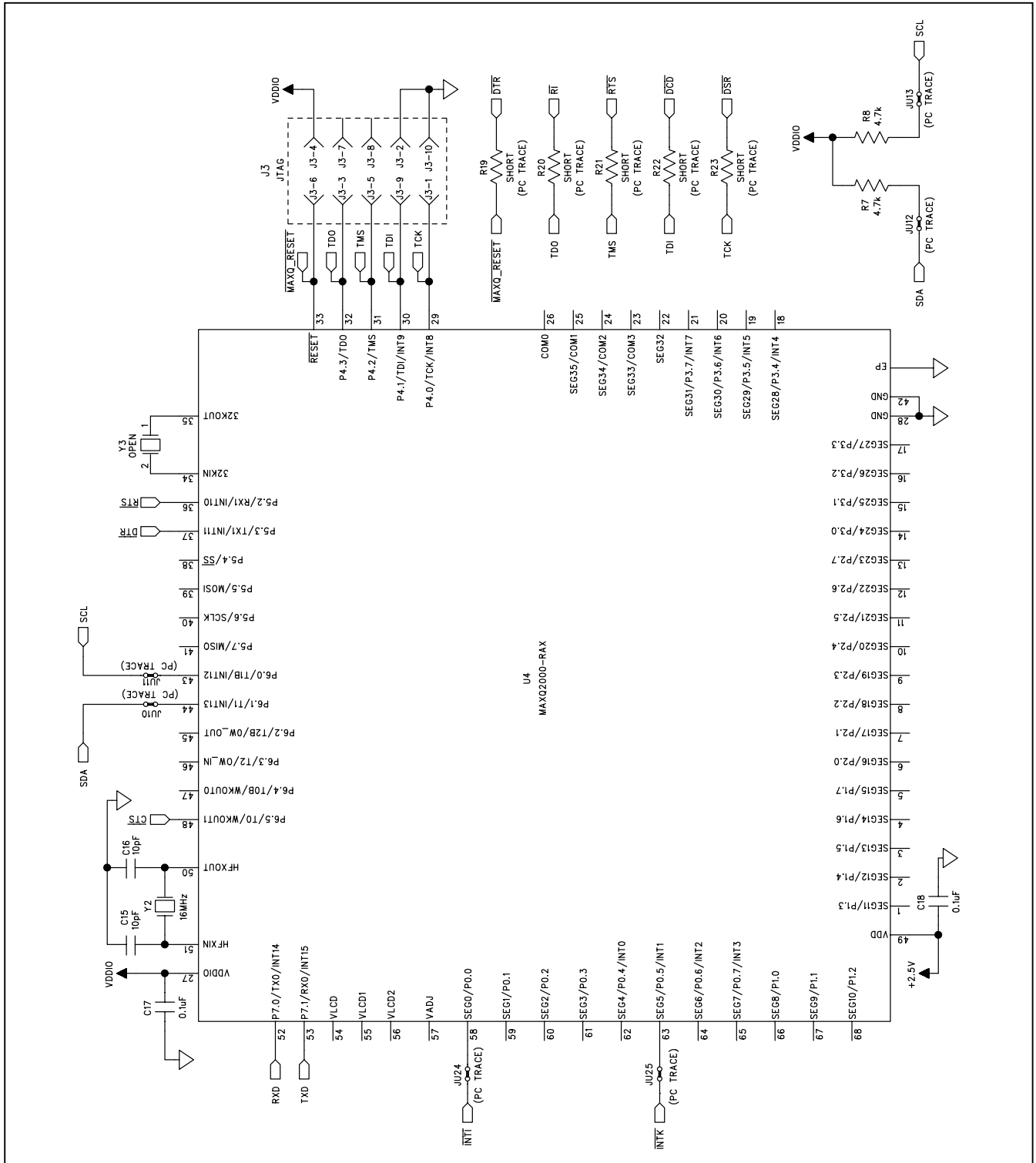

Figure 6d. MAX7360 EV Kit Schematic (Sheet 4 of 5)





# MAX7360 Evaluation Kit

## Evaluates: MAX7360

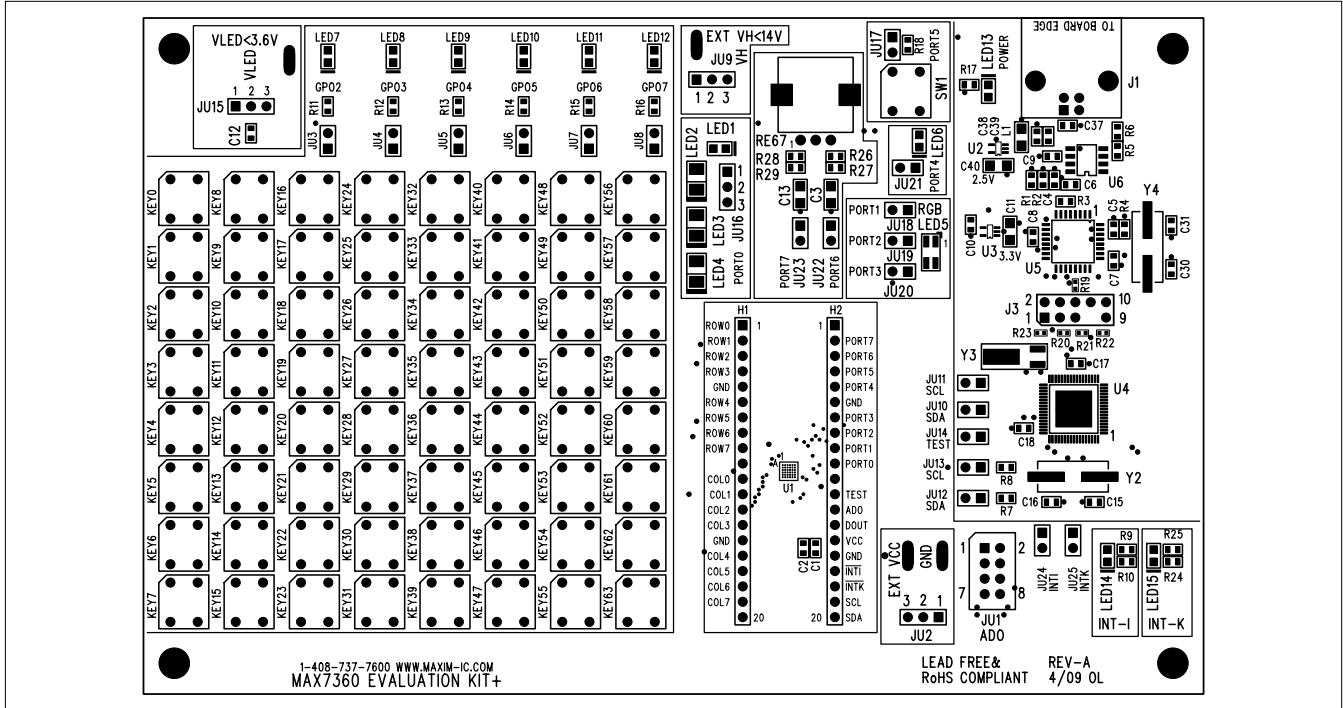

Figure 7. MAX7360 EV Kit Component Placement Guide—Component Side

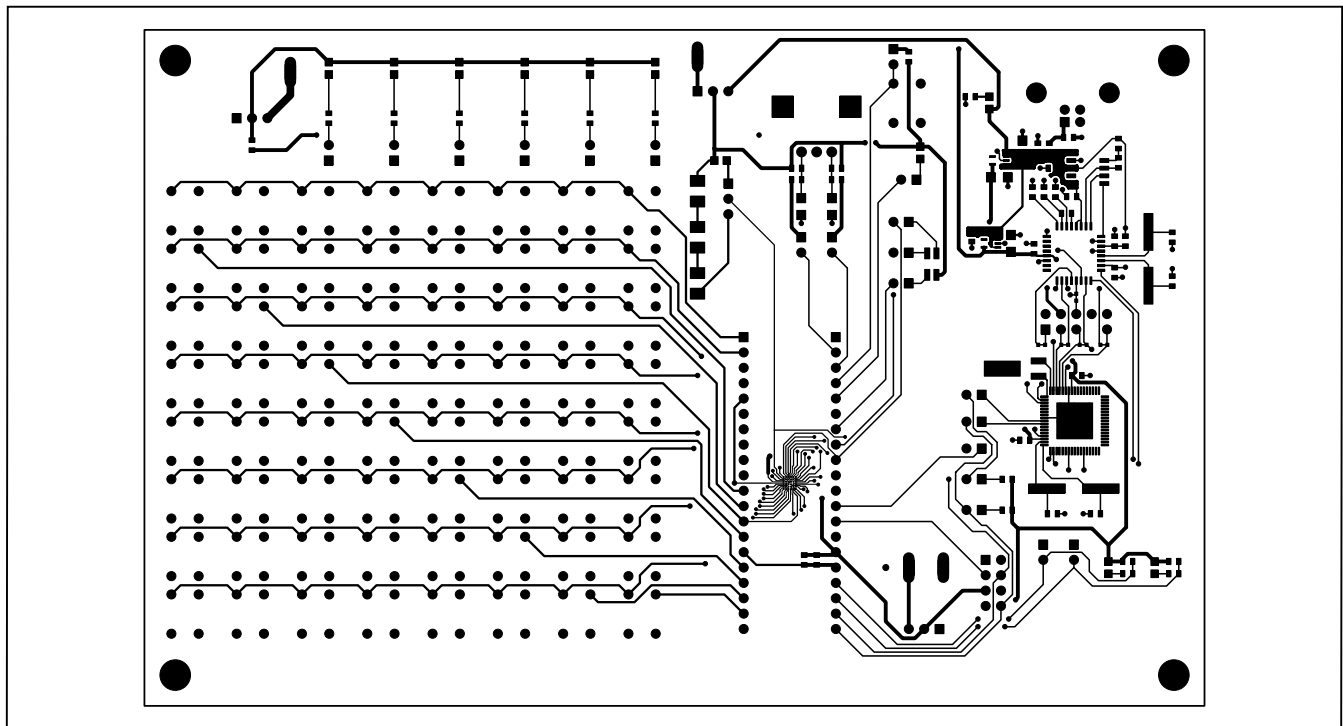

Figure 8. MAX7360 EV Kit PCB Layout—Component Side

# MAX7360 Evaluation Kit

## Evaluates: MAX7360

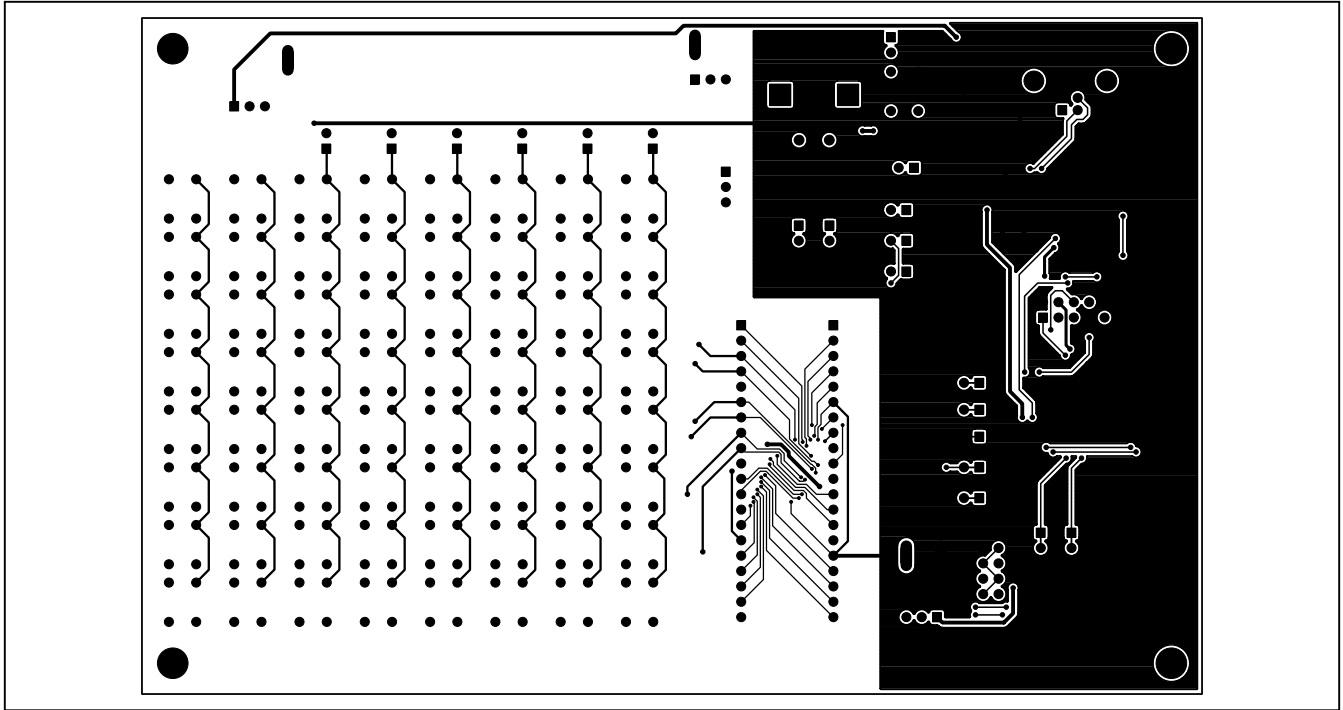

Figure 9. MAX7360 EV Kit PCB Layout—Solder Side



Maxim Integrated cannot assume responsibility for use of any circuitry other than circuitry entirely embodied in a Maxim Integrated product. No circuit patent licenses are implied. Maxim Integrated reserves the right to change the circuitry and specifications without notice at any time. The parametric values (min and max limits) shown in the Electrical Characteristics table are guaranteed. Other parametric values quoted in this data sheet are provided for guidance.